



# Getting Started with Q3D Extractor: A 3D PCB Via Model



ANSYS, Inc.  
Southpointe  
2600 Ansys Drive  
Canonsburg, PA 15317  
[ansysinfo@ansys.com](mailto:ansysinfo@ansys.com)  
<https://www.ansys.com>  
(T) 724-746-3304  
(F) 724-514-9494

Release  
2024 R2

July 2024

ANSYS, Inc. and ANSYS  
Europe, Ltd. are UL  
registered ISO 9001:2015  
companies.

## Copyright and Trademark Information

© 1986-  
2024

ANSYS, Inc. Unauthorized use, distribution or duplication is prohibited.

ANSYS, Ansys Workbench, AUTODYN, CFX, FLUENT and any and all ANSYS, Inc. brand, product, service and feature names, logos and slogans are registered trademarks or trademarks of ANSYS, Inc. or its subsidiaries located in the United States or other countries. ICEM CFD is a trademark used by ANSYS, Inc. under license. All other brand, product, service and feature names or trademarks are the property of their respective owners. FLEXlm and FLEXnet are trademarks of Flexera Software LLC.

## Disclaimer Notice

THIS ANSYS SOFTWARE PRODUCT AND PROGRAM DOCUMENTATION INCLUDE TRADE SECRETS AND ARE CONFIDENTIAL AND PROPRIETARY PRODUCTS OF ANSYS, INC., ITS SUBSIDIARIES, OR LICENSORS. The software products and documentation are furnished by ANSYS, Inc., its subsidiaries, or affiliates under a software license agreement that contains provisions concerning non-disclosure, copying, length and nature of use, compliance with exporting laws, warranties, disclaimers, limitations of liability, and remedies, and other provisions. The software products and documentation may be used, disclosed, transferred, or copied only in accordance with the terms and conditions of that software license agreement.

ANSYS, Inc. and ANSYS Europe, Ltd. are UL registered ISO 9001: 2015 companies.

## U.S. Government Rights

For U.S. Government users, except as specifically granted by the ANSYS, Inc. software license agreement, the use, duplication, or disclosure by the United States Government is subject to restrictions stated in the ANSYS, Inc. software license agreement and FAR 12.212 (for non-DOD licenses).

## Third-Party Software

See the legal information in the product help files for the complete Legal Notice for Ansys proprietary software and third-party software. If you are unable to access the Legal Notice, please contact ANSYS, Inc.

## Conventions Used in this Guide

Please take a moment to review how instructions and other useful information are presented in this documentation.

- Procedures are presented as numbered lists. A single bullet indicates that the procedure has only one step.
- Bold type is used for the following:
  - Keyboard entries that should be typed in their entirety exactly as shown. For example, “**copy file1**” means you must type the word **copy**, then type a space, and then type **file1**.
  - On-screen prompts and messages, names of options and text boxes, and menu commands. Menu commands are often separated by greater than signs (>). For example, “click **HFSS > Excitations > Assign > Wave Port.**”
  - Labeled keys on the computer keyboard. For example, “Press **Enter**” means to press the key labeled **Enter**.
- Italic type is used for the following:
  - Emphasis.
  - The titles of publications.
  - Keyboard entries when a name or a variable must be typed in place of the words in italics. For example, “**copy filename**” means you must type the word **copy**, then type a space, and then type the name of the file.
- The plus sign (+) is used between keyboard keys to indicate that you should press the keys at the same time. For example, “Press Shift+F1” means to press the **Shift** key and, while holding it down, press the **F1** key also. You should always depress the modifier key or keys first (for example, Shift, Ctrl, Alt, or Ctrl+Shift), continue to hold it/them down, and then press the last key in the instruction.

**Accessing Commands:** *Ribbons*, *menu bars*, and *shortcut menus* are three methods that can be used to see what commands are available in the application.

- The *Ribbon* occupies the rectangular area at the top of the application window and contains multiple tabs. Each tab has relevant commands that are organized, grouped, and labeled. An example of a typical user interaction is as follows:

"Click **Draw > Line**"



This instruction means that you should click the **Line** command on the **Draw** ribbon tab. An image of the command icon, or a partial view of the ribbon, is often included with the instruction.

- The *menu bar* (located above the ribbon) is a group of the main commands of an application arranged by category such File, Edit, View, Project, etc. An example of a typical user interaction is as follows:

"On the **File** menu, click the **Open Examples** command" means you can click the **File** menu and then click **Open Examples** to launch the dialog box.

- Another alternative is to use the *shortcut menu* that appears when you click the right-mouse button. An example of a typical user interaction is as follows:

"Right-click and select **Assign Excitation> Wave Port**" means when you click the right-mouse button with an object face selected, you can execute the excitation commands from the shortcut menu (and the corresponding sub-menus).

### Getting Help: Ansys Technical Support

For information about Ansys Technical Support, go to the Ansys corporate Support website, <http://www.ansys.com/Support>. You can also contact your Ansys account manager in order to obtain this information.

All Ansys software files are ASCII text and can be sent conveniently by e-mail. When reporting difficulties, it is extremely helpful to include very specific information about what steps were taken or what stages the simulation reached, including software files as applicable. This allows more rapid and effective debugging.

### Help Menu

To access help from the Help menu, click **Help** and select from the menu:

- **[product name] Help** - opens the contents of the help. This help includes the help for the product and its *Getting Started Guides*.
- **[product name] Scripting Help** - opens the contents of the *Scripting Guide*.
- **[product name] Getting Started Guides** - opens a topic that contains links to Getting Started Guides in the help system.

### Context-Sensitive Help

To access help from the user interface, press **F1**. The help specific to the active product (design type) opens.

You can press **F1** while the cursor is pointing at a menu command or while a particular dialog box or dialog box tab is open. In this case, the help page associated with the command or open dialog box is displayed automatically.

# Table of Contents

<b>Table of Contents</b> .....	<b>Contents-1</b>
<b>1 - Introduction</b> .....	<b>1-1</b>
The Via Model .....	1-1
<b>2 - Creating the Via Model</b> .....	<b>2-1</b>
Creating and Saving a New Project .....	2-1
Setting Drawing Units .....	2-2
Enabling Legacy View Orientation .....	2-3
Drawing the Model .....	2-4
Creating the Via's Central Barrel .....	2-5
Creating the First Via Pad .....	2-6
Duplicating the First Via Pad .....	2-7
Creating Geometric Variables .....	2-8
Assigning a Variable to the Center Barrel .....	2-11
Assigning a Variable to the Pads .....	2-13
Drawing the Trace Stubs .....	2-18
Uniting Via Objects .....	2-20
Creating the Ground Plane .....	2-22
Creating the Antipad .....	2-24
Setting the Background Material .....	2-26
<b>3 - Setting Up the Simulation and Viewing Results</b> .....	<b>3-1</b>
Changing Q3D Design Settings .....	3-1
Setting Up Sources and Sinks .....	3-2
Defining the Source .....	3-3
Assigning the Sink .....	3-4
Identifying the Nets .....	3-6
Adding a Solution Setup .....	3-7

Validating the Design .....	3-9
Launching the Simulation .....	3-9
Generating a Field Plot .....	3-11
Exporting a Circuit Model .....	3-12
<b>4 - Setting Up a Parametric Analysis .....</b>	<b>4-1</b>
Adding a Parametric Sweep .....	4-1
Running the Parametric Analysis .....	4-3
<b>5 - Comparing Results .....</b>	<b>5-1</b>
Plotting the Results .....	5-1
Modifying the Pad Radius .....	5-2
Running and Plotting Second Parametric Analysis .....	5-3
<b>6 - Closing the Project and Exiting Electronics Desktop .....</b>	<b>6-1</b>

# 1 - Introduction

This *Getting Started Guide* leads you step-by-step through creating, solving, and analyzing the results of a parameterized 3D model representing a via on a Printed Circuit Board.

This guide outlines how to perform the following tasks in Q3D:

- Drawing a geometric model
- Setting up vias and traces
- Modifying a model's design parameters
- Assigning variables to a model's design parameters
- Specifying solution and design settings
- Validating a design's setup
- Running a simulation
- Creating a plot of results

## The Via Model

The via consists of a central cylinder and three thin cylindrical copper pads. It passes through a clearance hole (antipad) in a large copper ground plane. The entire structure is embedded in an FR-4 dielectric material.

The via model is shown below.

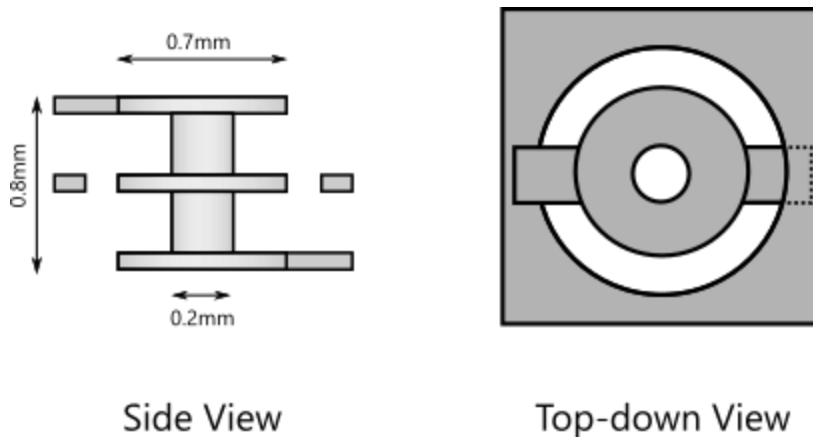

You will extract the parasitic inductance, resistance, and capacitance of this via. The drill hole radius and the pad radius should be made variable quantities so that you can conduct a parametric study of their effects.



## 2 - Creating the Via Model

This section explains how to perform the following tasks:

- Creating and saving a new project
- Setting the model units for the design
- Drawing a model
- Creating and assigning variables
- Setting the background material

### Creating and Saving a New Project

A project is a collection of one or more designs that is saved in a single file. A new, blank project is automatically created when Electronics Desktop is launched.

To launch Electronics Desktop, add a Q3D design, and save a new project:

1. Double-click the **Ansys Electronics Desktop** icon on your desktop.

A new project appears in the **Project Manager** window, named **Project#**. The number depends on the number of projects previously saved. Beneath the project are folders containing project definitions.

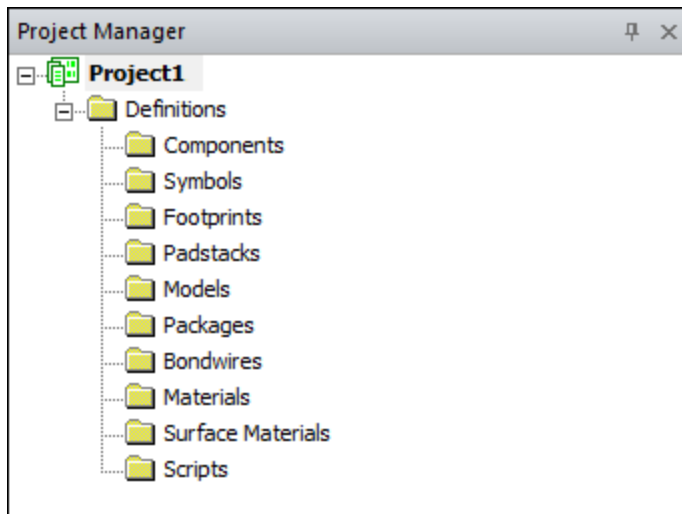

2. Select **Project > Insert Q3D Design**.

A Q3D design appears beneath the project name, named Q3DDesign#. The number depends on the number of designs previously added to the project.

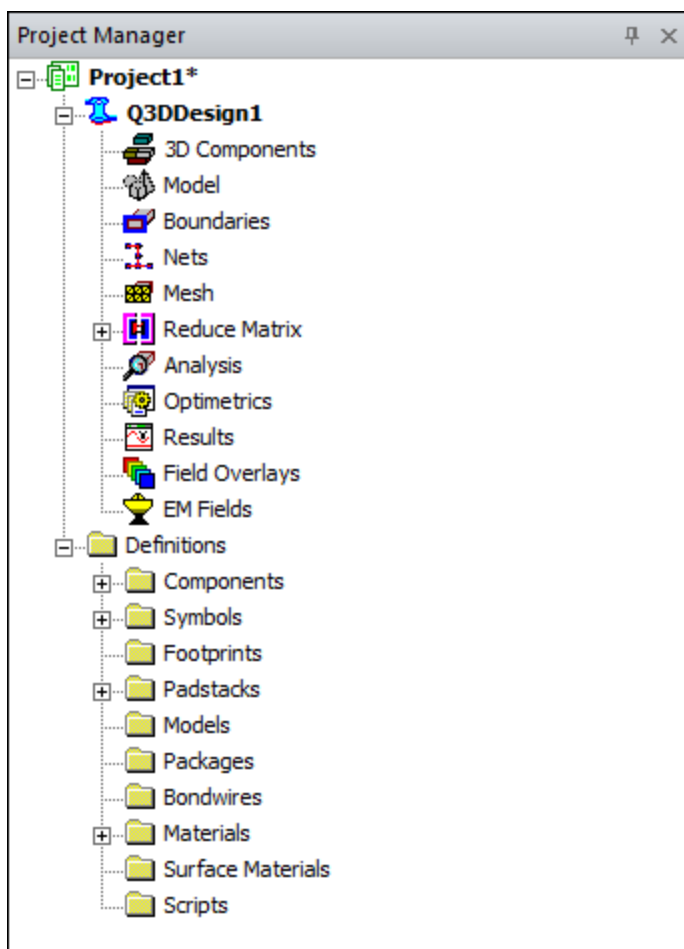

An asterisk (\*) next to the project name means there are unsaved changes.

3. Click **File > Save As**.

The **Save As** dialog box appears.

4. Select a location to save the file.
5. In the **File Name** field, type `via_gsg` and click **Save**.

The project is saved as `via_gsg.aedt` in the folder you selected.

6. Rename the default design:
  - a. From the **Project Manager** window, right-click **Q3DDesign1** and select **Rename**.
  - b. Type `ViaModel` and press **Enter**.

## Setting Drawing Units

To set the model's unit of measure:

1. Click **Modeler > Units**.

The **Set Model Units and Max Extent** dialog box appears.

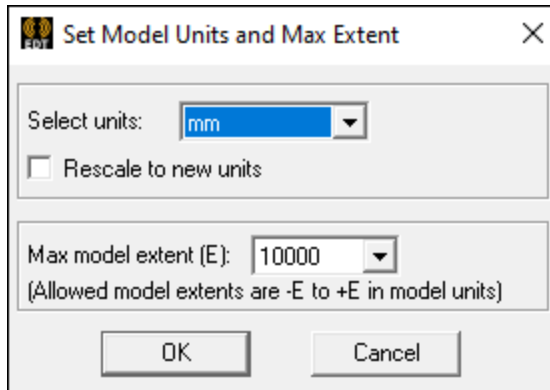

2. Verify that **mm** is selected in the **Select units** drop-down list.
3. Click **OK**.

## Enabling Legacy View Orientation

To ensure that your modeling window resembles the screenshots in this Getting Started Guide:

1. Select **View > Options**.
2. On the **General** tab, ensure that **Enable Legacy View Orientation** is selected.

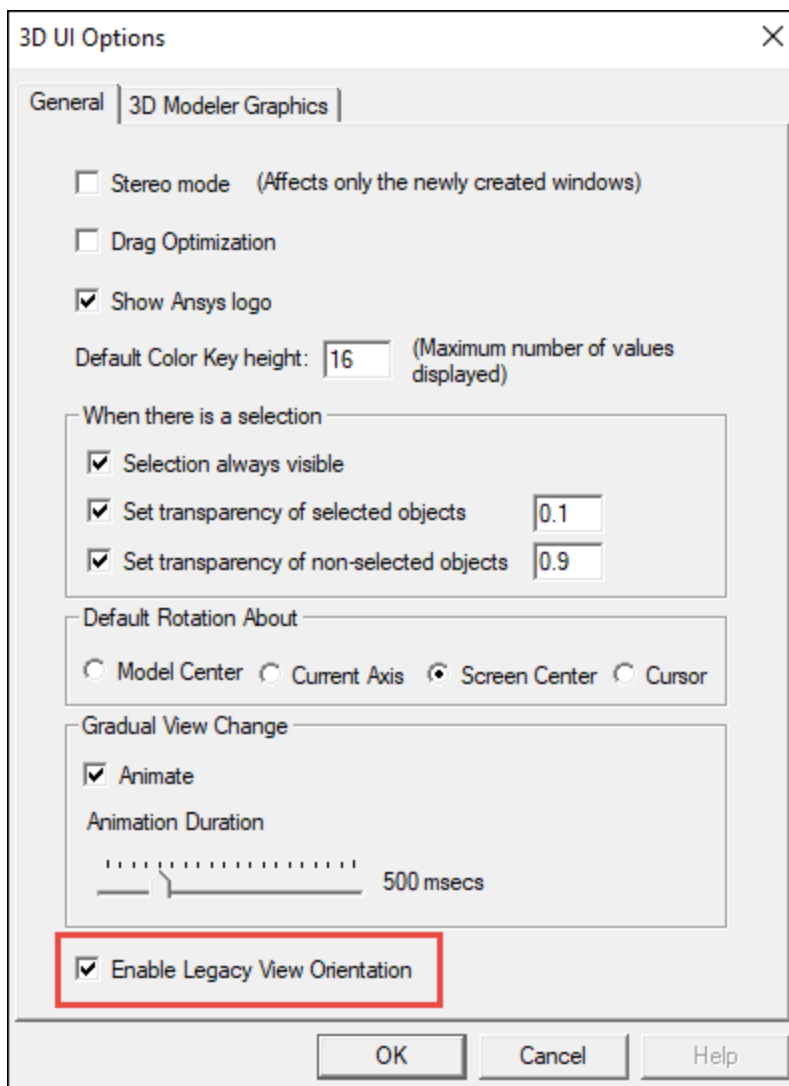

For more information on Legacy View, consult the Q3D Extractor help topic "View Options: 3D UI Options."

## Drawing the Model

Drawing this model consists of the following steps:

1. Drawing a cylinder for the via's central barrel.
2. Drawing a cylinder for the via pad.
3. Duplicating the via pad to create two additional pads.

4. Drawing boxes for trace stubs.
5. Uniting the via pieces into a single object.
6. Drawing a box for the ground plane.
7. Drawing a cylinder for the antipad.

As you follow these steps, this section will also show you how to create and apply design variables.

## Creating the Via's Central Barrel

Create the first cylinder:

1. Click **Draw > Cylinder**.

The **Measure Data** dialog box appears.

2. Specify the radius:
  - a. Click at the origin of the XYZ coordinate system.

**Important:**

Do not move your cursor while specifying the information below.

- b. Press **Tab** to move the cursor to the **dX** field.
  - c. Type **0.2** in the **dX** field, and then press **Tab** to move to the **dY** box.
  - d. Type **0.0** in the **dY** field, and then press **Tab** to move to the **dZ** box.
  - e. Type **0.0** in the **dZ** field, and press **Enter**.

The radius of the cylinder becomes fixed, and the height of the cylinder changes dynamically as you move the cursor.

3. Specify the height of the cylinder:
  - a. Move the cursor over the z-axis.
  - b. Click when **dZ** displays **0.8**.

The History Tree updates to display the **CreateCylinder** command. This command can also be viewed in the **Properties** window, on the **Command** tab.

The **Properties** window's **Attribute** tab displays information about the newly created **Cylinder1** object.

4. If it is not already selected, click the **Attribute** tab to see the properties associated with the cylinder.
5. Change the name of the cylinder to **Via**:
  - a. Click the **Value** text box in the **Name** row.
  - b. Type **Via**, and press **Enter**.

6. In the **Value** text box in the **Material** row, verify that the material type is **copper**.
7. Click **OK**.

## Creating the First Via Pad

Now you will create another cylinder to represent the via pad.

1. Click **Draw > Cylinder**.
2. Create a cylinder by specifying the radius and height:
  - a. Click at the origin of the XYZ coordinate system.

**Important:**

Do not move your cursor while specifying the information below.

- b. Press **Tab** to move the cursor to the **dX** field.
  - c. Type **0.6** in the **dX** field, and then press **Tab** to move to the **dY** box.
  - d. Type **0.0** in the **dY** field, and then press **Tab** to move to the **dZ** box.
  - e. Type **0.025** in the **dZ** field, and press **Enter**.
3. Click on the **Properties** window's **Attribute** tab to see all the properties associated with the cylinder.
4. Change the name of the cylinder to **Pad1**.
5. In the **Value** text box in the **Material** row, verify that the material type is **copper**.
6. Click **OK**.

After these steps, your model should look similar to:

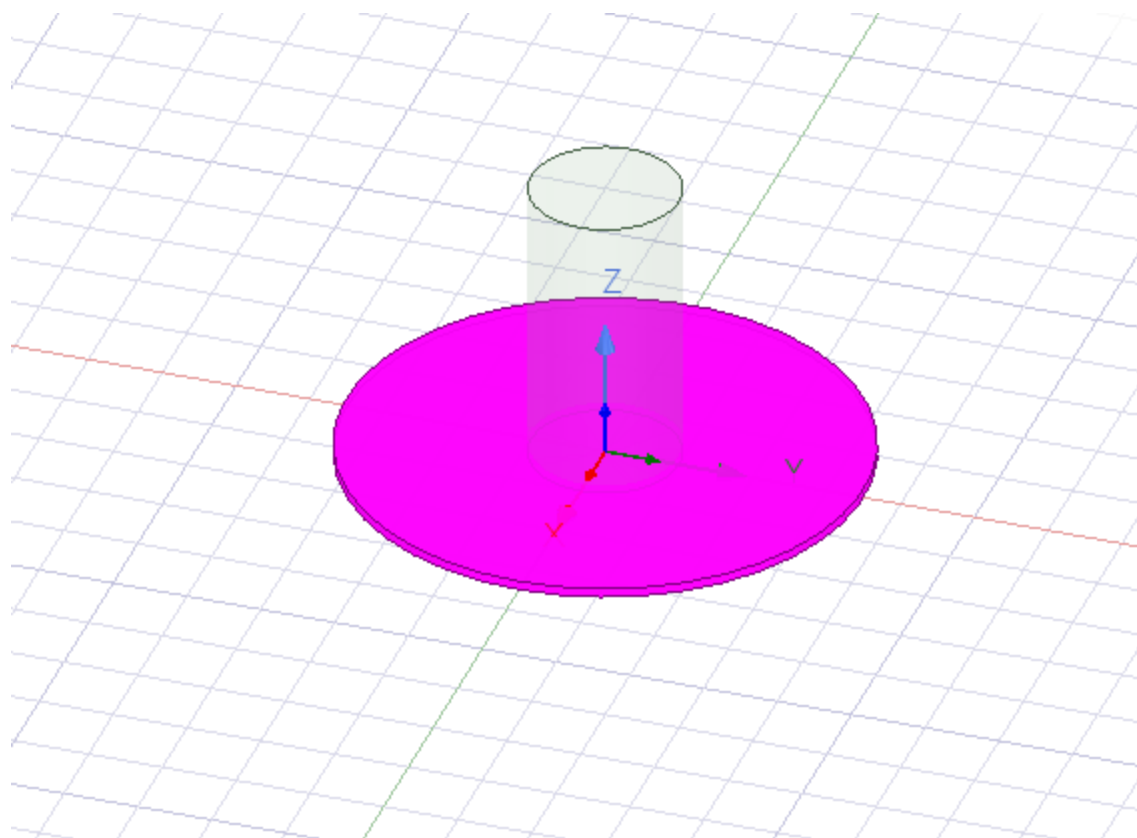

## Duplicating the First Via Pad

Now you will create two more via pads from the first one.

1. Click **Pad1** in the modeling workspace.
2. Click **Edit > Duplicate > Along Line**.
3. Specify the distance between pads as 0.4mm:
  - a. Click at the origin of the XYZ coordinate system.

**Important:**

Do not move your cursor while specifying the information below.

- b. Press **Tab** to move to the **dX** field.
- c. Type **0** in the **dX** field, and then press **Tab** to move to the **dY** box.
- d. Type **0** in the **dY** field, and then press **Tab** to move to the **dZ** box.
- e. Type **0.4** in the **dZ** field, and press **Enter**.

The **Duplicate along line** dialog box appears, and the model updates to preview the duplication.

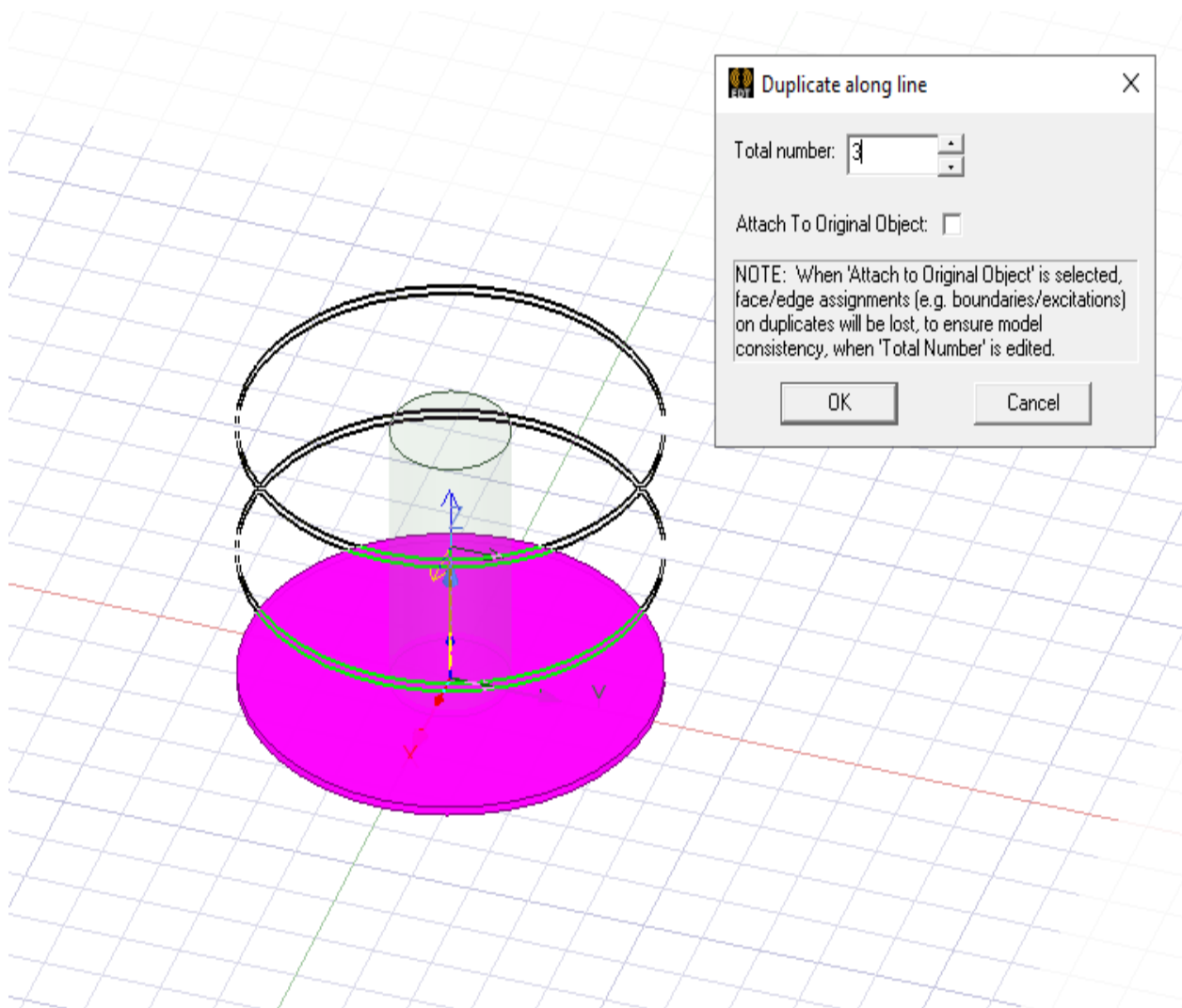

4. Type **3** in the **Total number** box.
5. Ensure that **Attach to Original Object** is *not* selected.
6. Click **OK**.

**Pad1** is duplicated 2 times. By default, the new objects are called **Pad1\_1** and **Pad1\_2**.

## Creating Geometric Variables

You will now define variables for the radius of the center barrel and the pads. Later, you will modify their values.

1. Click **Q3D Extractor > Design Properties**.

The **Properties** window appears, with no data listed.

2. Click **Add**.

The **Add Property** window appears.

3. Type **viarad** in the **Name** box.
4. Use the **Unit Type** drop-down menu to select **Length**.
5. Use the **Units** drop-down menu to select **mm**.
6. Type **0.2** in the **Value** box.

The screenshot shows the 'Add Property' dialog box with the following fields and options:

- Name:** viarad
- Unit Type:** Length
- Units:** mm
- Value:** 0.2
- Radio Buttons:** Variable (selected), Separator, PostProcessingVariable
- Text Box:** Enter initial value into Value field. This should be a number, variable, or expression. Referenced project variables should be prefixed with a '\$'. Examples: 22.4pF, \$C1, 2\*cos(\$x).
- Buttons:** OK, Cancel

7. Click **OK**.

The **Properties** window updates to display the new variable.

8. Click **Add** again.
9. In the **Add Property** window:
  - a. Type **padrad** in the **Name** box.
  - b. Use the **Unit Type** drop-down menu to select **Length**.
  - c. Use the **Units** drop-down menu to select **mm**.

- d. Type **0.6** in the **Value** box.

Add Property

Name   Variable  Separator  PostProcessingVariable  
 ArrayIndexVariable

Unit Type  Units

Value

Enter initial value into Value field. This should be a number, variable, or expression. Referenced project variables should be prefixed with a '\$'. Examples: 22.4pF, \$C1, 2\*cos(\$x).

- e. Click **OK** to add the variable and return to the **Properties** window.

Both new variables are listed.

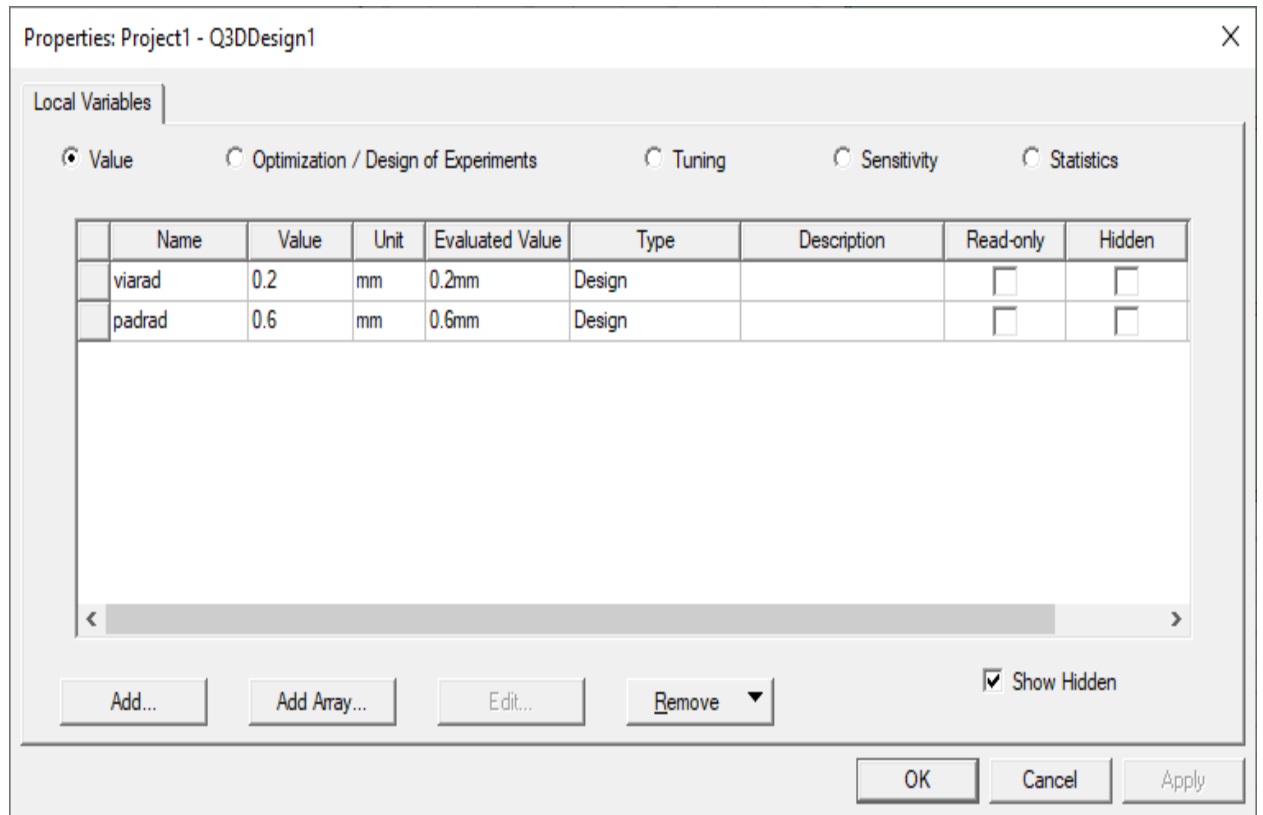

10. Click **OK** to close the **Properties** window and return to the model.

## Assigning a Variable to the Center Barrel

After you have defined the variables, you will need to assign them.

You previously specified the via's radius to be 0.2mm.

You will now replace that value with the **viarad** variable:

1. From the History Tree, select the **CreateCylinder** action under **Via**.

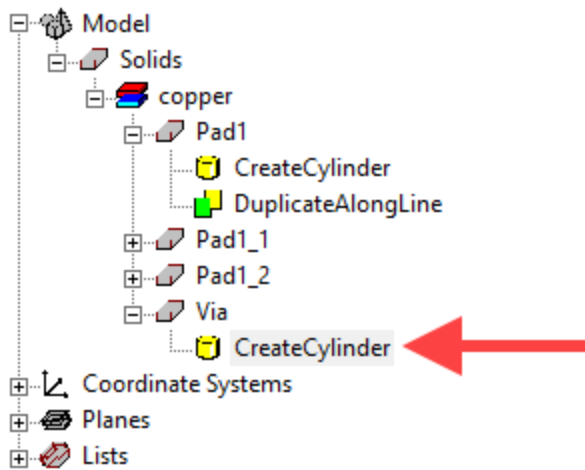

The **Properties** window updates to display a **Command** tab.

2. Assign the variable **viarad** to the radius:

- a. In the **Radius** row, click the **Value** field.
- b. Type **viarad**, and press **Enter**.

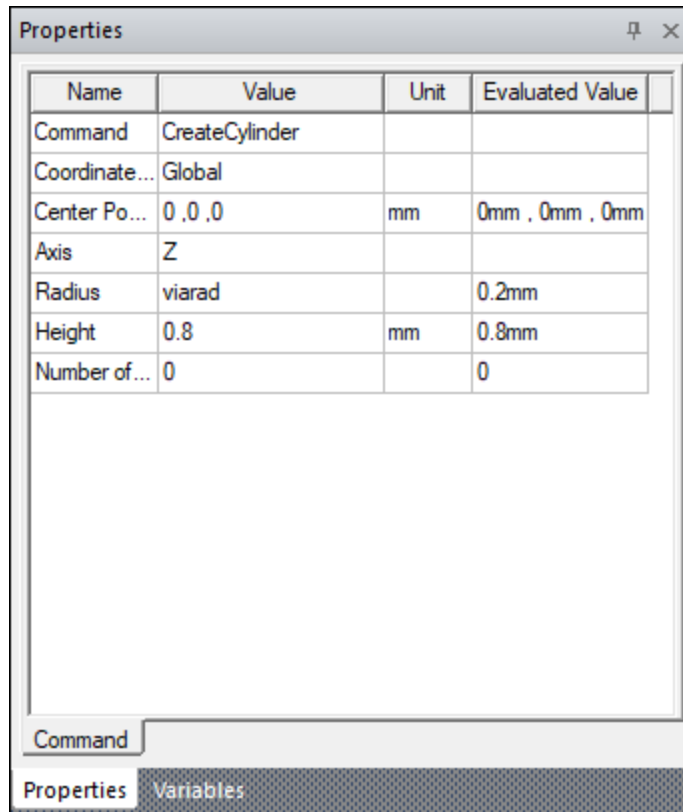

The **Properties** window updates, but the modeling workspace remains unchanged because the variable holds the same value.

## Assigning a Variable to the Pads

You previously specified the pad's radius to be 0.6mm.

You will now replace that value with the **padrad** variable:

1. From the History Tree, select the **CreateCylinder** action under **Pad1**.

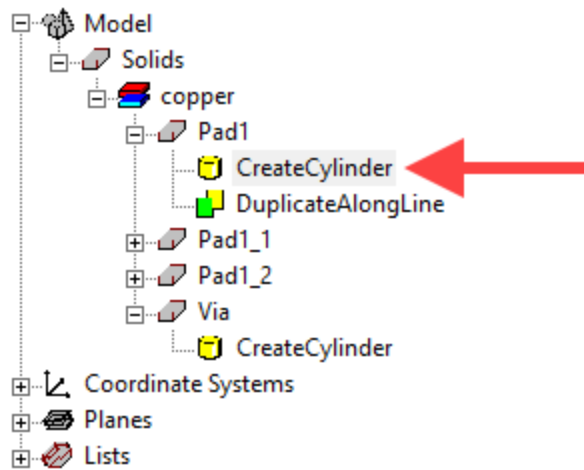

The **Properties** window updates to display the **Command** tab.

2. Assign the variable **padrad** to the radius:
  - a. In the **Radius** row, click the **Value** field.
  - b. Type **padrad**, and press **Enter**.

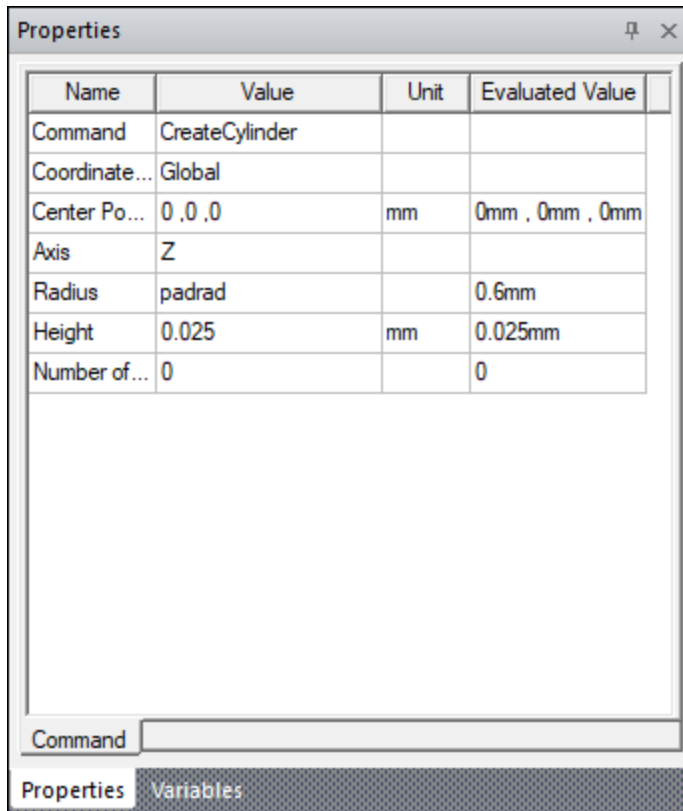

The **Properties** window updates, but the modeling workspace remains unchanged because the variable holds the same value.

3. Click **Q3D Extractor > Design Properties**.

The **Properties** window appears.

4. In the padrad row, type **0.5** in the **Value** field.

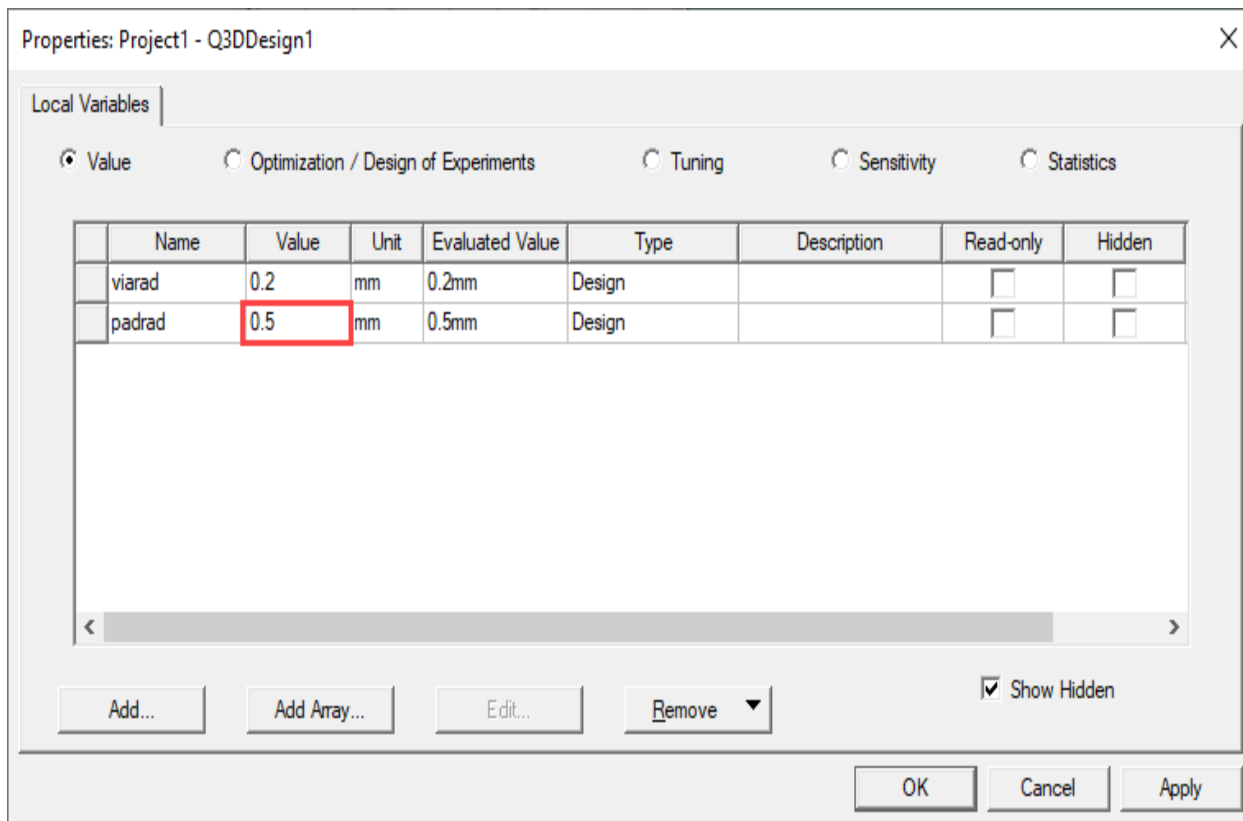

5. Click **OK**.

The model updates. The radius changes for all three of the pads, since **Pad1\_1** and **Pad1\_2** inherit changes to **Pad1**.

6. Click **Q3D Extractor > Design Properties** to reopen the **Properties** window.

7. Reset the **Value** of **padrad** to **0.6**, and verify that the **Value** for **viarad** is set to **0.2**.

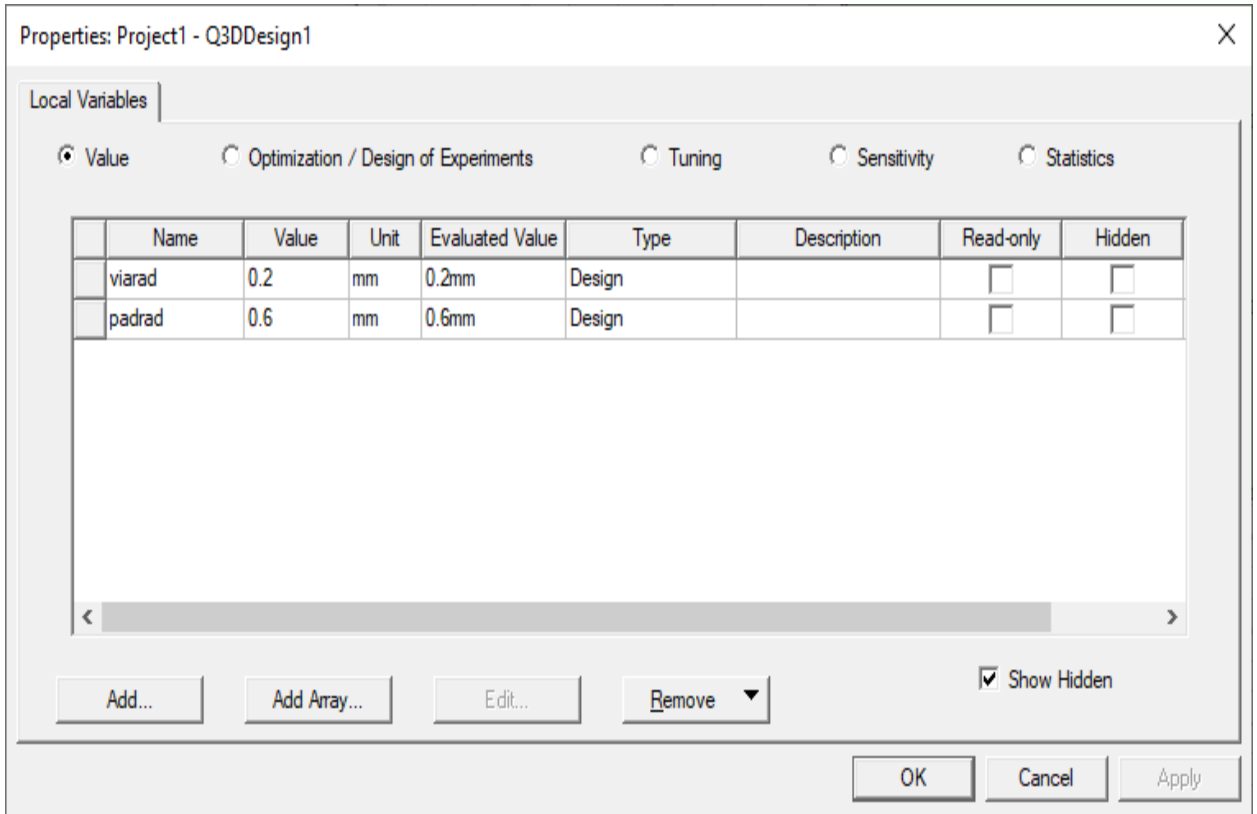

The model should look like the following:

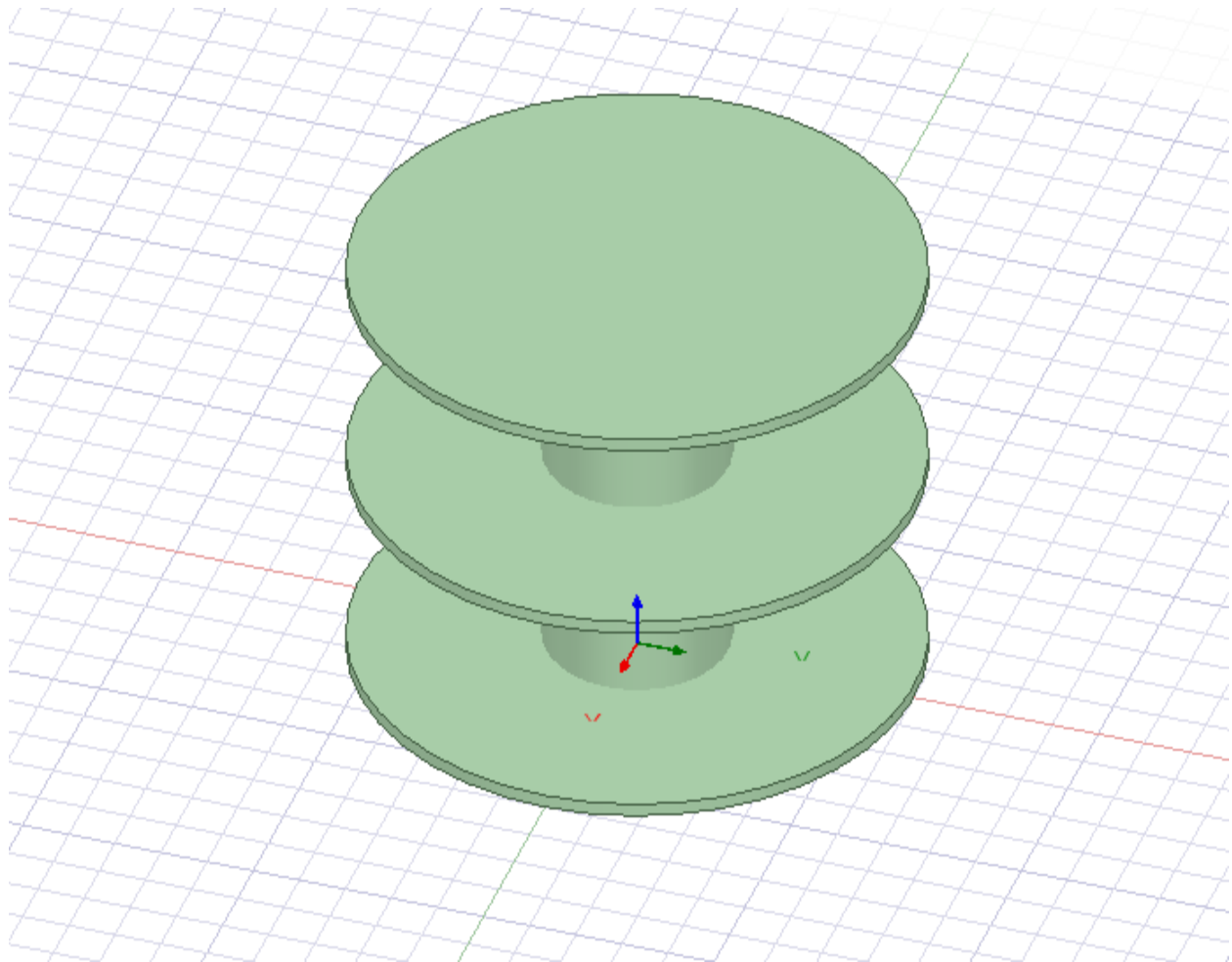

## Drawing the Trace Stubs

You will now add some trace stubs to the via model. Draw stubs to represent traces connecting to the top and bottom of the via.

1. Click **Draw > Box**.
2. Use the status bar to specify the location of the base corner of the box (-0.25, 0.4, 0):

### Important:

Do not move your cursor while specifying the information below.

- a. Press **Tab** to move to the **X** box in the status bar.
- b. Type **-0.25** in the **X** field, and then press **Tab** to move to the **Y** field.

- c. Type **0.4** in the **Y** field, and then press **Tab**.
  - d. Type **0** in the **Z** field, and then press **Enter**.
3. Without moving your cursor, continue using the status bar to specify the dimensions of the box:
    - a. Press **Tab** to move to the **dX** field in the status bar.
    - b. Type **0.5** in the **dX** field, and then press **Tab** to move to the **dY** field.
    - c. Type **1.2** in the **dY** box, and then press **Tab**.
    - d. Type **0.025** in the **dZ** box and then press **Enter**.

A new object called **Box1** is created.

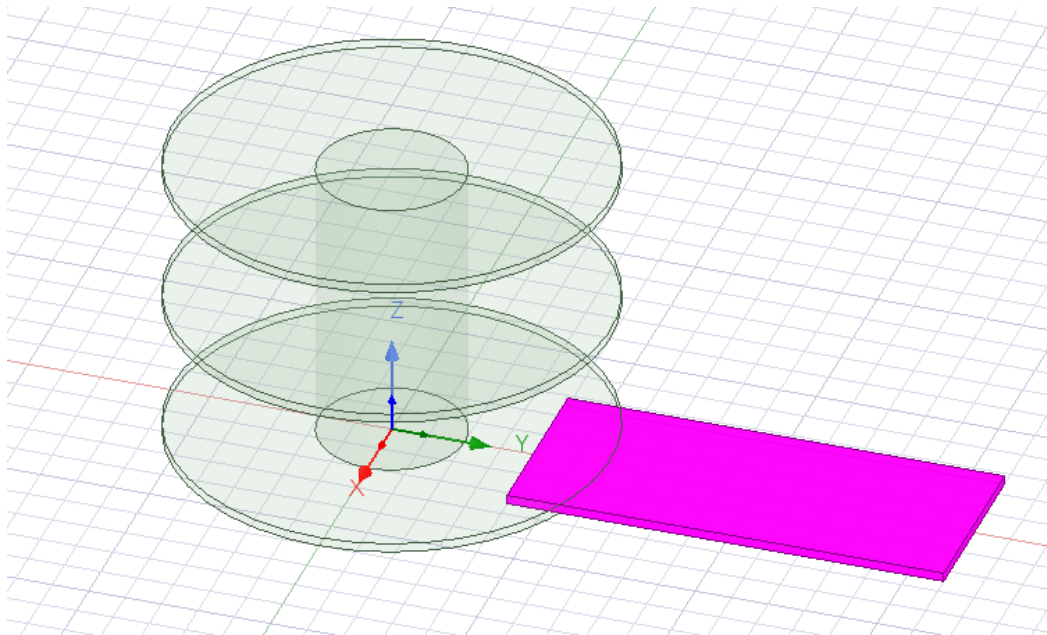

The **Attribute** tab of the **Properties** window displays the details for **Box1**.

4. Verify that the **Material** for **Box1** is set to **copper**.
5. Repeat steps 1 through 3 to create another box, **Box2**. This box should have the following values:

X = -0.25	Y = - 0.4	Z = 0.8
dX = 0.5	dY = - 1.2	dZ = 0.025

The model should look like the following:

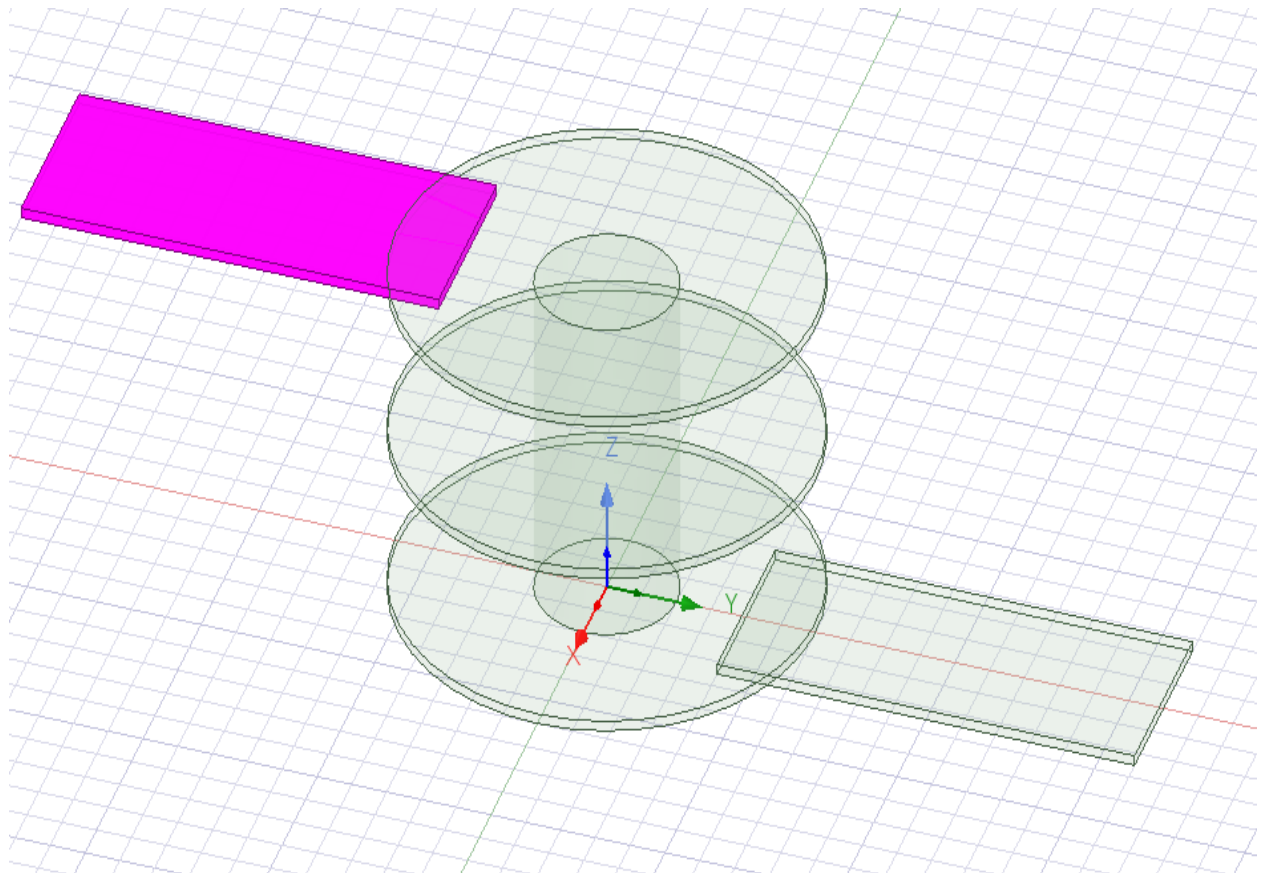

The trace stubs created here partially overlap the pads. The via's center barrel also overlaps the pad objects.

Partially overlapping objects can create ambiguity about the type of material to be used in the overlap region. In the special case of one object being completely contained within another, it is assumed that the material of the smaller object applies within the overlap region. This is the only case in which overlapping objects are allowed.

## Uniting Via Objects

The partial overlaps between the various objects in this model must be eliminated.

Since all the objects are of the same material (copper), you can unite them into a single solid object:

1. Click **Edit > Select All**.
2. Click **Modeler > Boolean > Unite**.

The list of objects is replaced by a single object named **Box2** that occupies the same volume of space as the original set of objects.

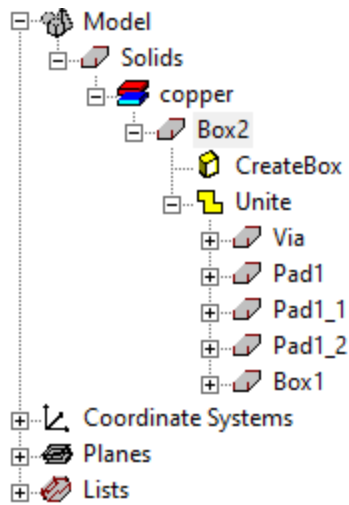

The material type of **Box2** is **copper**.

3. In the **Properties** window, use the **Name** field to rename **Box2** to **Via1**.

The **Modeler** window should look like the following:

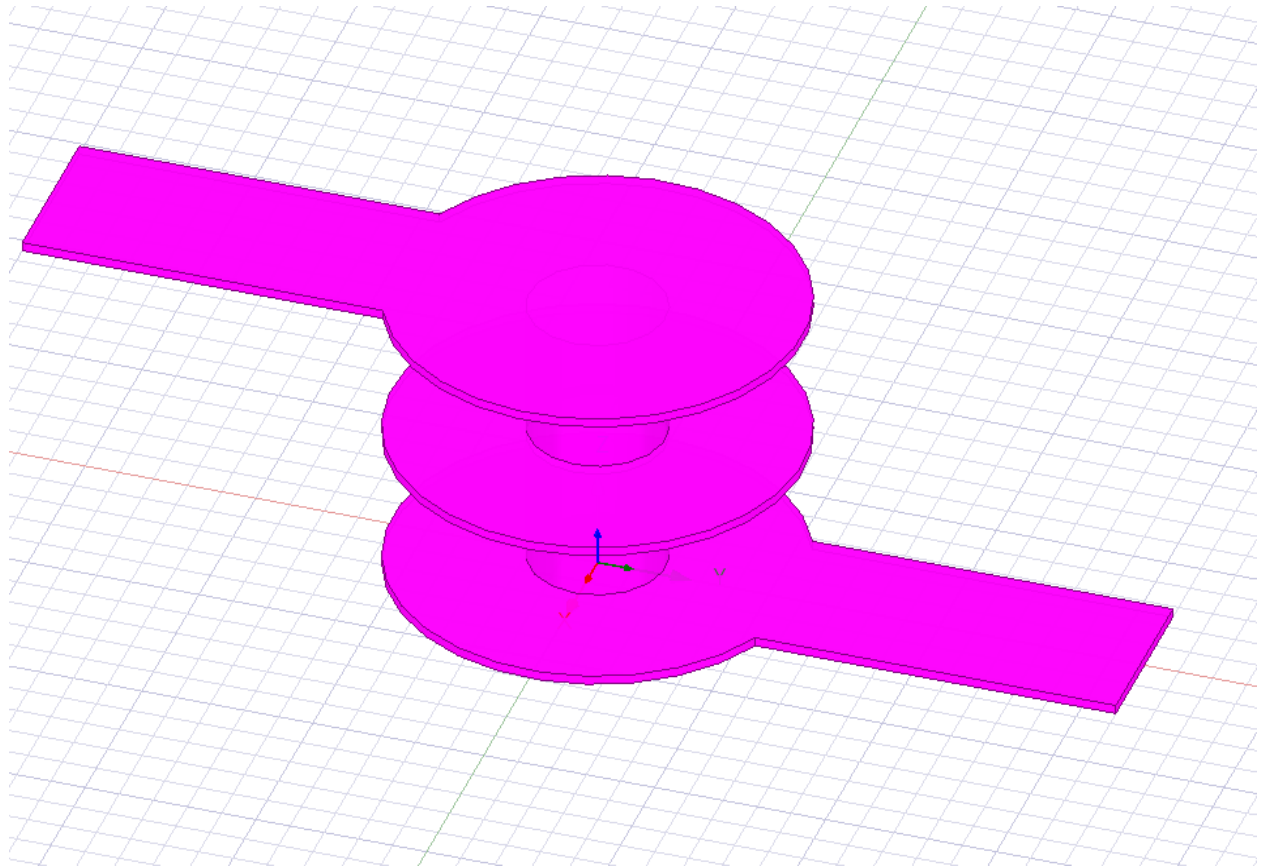

## Creating the Ground Plane

You will create the ground plane as a box:

1. Click **Draw > Box**.  
The **Measure Data** dialog box appears.
2. Specify the base corner of the box:
  - a. Press **Tab** to move the cursor to the **X** field.

**Important:**

Do not move your cursor while specifying the information below.

- b. Type **-5** in the **X** field, and then press **Tab** to move to the **dY** box.
    - c. Type **-5** in the **Y** field, and then press **Tab** to move to the **dZ** box.
    - d. Type **0.4** in the **Z** field, and press **Enter**.

3. Specify the dimensions of the box:
  - a. Press **Tab** to move the cursor to the **dX** field.

**Important:**

Do not move your cursor while specifying the information below.

- b. Type **10** in the **dX** field, and then press **Tab** to move to the **dY** box.
- c. Type **10** in the **dY** field, and then press **Tab** to move to the **dZ** box.
- d. Type **0.025** in the **dZ** field, and press **Enter**.

A new box named **Box2** is created.

4. Use the **Name** field in the **Properties** window to rename **Box2** to **GroundPlane**.
5. Set the modeling workspace to show the entire model by clicking **View > Fit All > Active View**.
6. To view model overlapping, make **GroundPlane** transparent:
  - a. Select **GroundPlane**.
  - b. In the **Properties** window, select the **Attribute** tab.
  - c. Click the Value box next to **Transparent**. By default, the box displays a 0.

The **Set Transparency** dialog box appears.

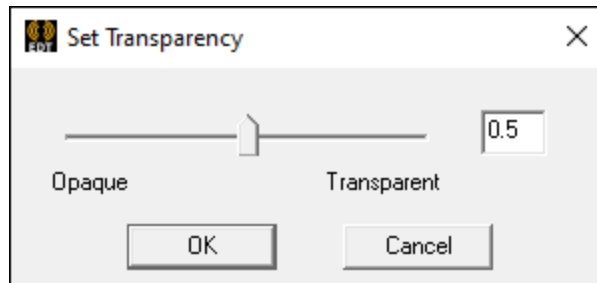

- d. Use the slider or enter 0.5 in the text field to set the value.
- e. Click **OK**.

The **Transparent** button in the **Properties** window updates to display 0.5.

The model updates to look like the following:

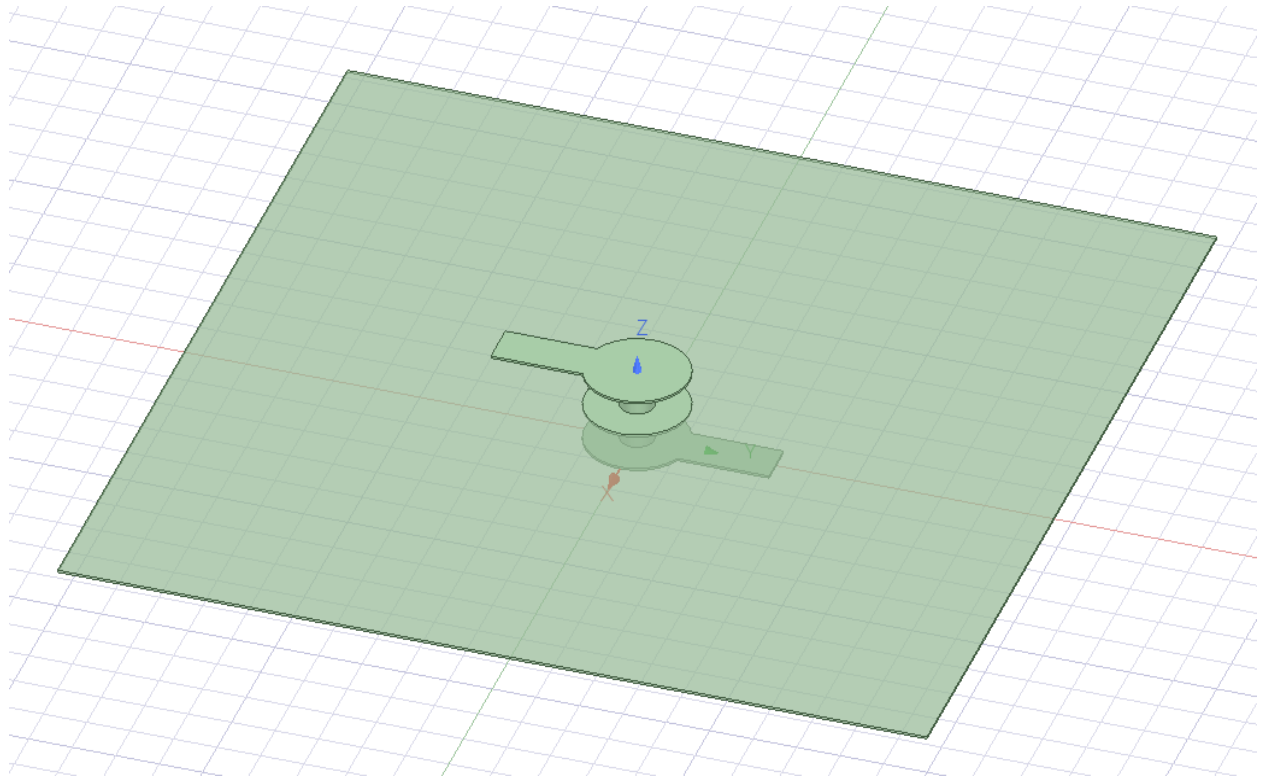

The overlap will be corrected in the next step.

## Creating the Antipad

To prevent the via from shorting to the ground plane, create a circular hole (or antipad) in the plane.

Create the first cylinder:

1. Click **Draw > Cylinder**.

The **Measure Data** dialog box appears.

### **Important:**

Do not move your cursor while specifying the information below.

2. Specify the location of the cylinder:
  - a. Press **Tab** to move the cursor to the **X** field.
  - b. Type **0.0** in the **X** field, and then press **Tab** to move to the **Y** box.
  - c. Type **0.0** in the **Y** field, and then press **Tab** to move to the **Z** box.
  - d. Type **0.4** in the **Z** field, and press **Enter**.

3. Specify the size of the cylinder:
  - a. Press **Tab** to move the cursor to the **dX** field.
  - b. Type **1.25** in the **dX** field, and then press **Tab** to move to the **dY** box.
  - c. Type **0** in the **dY** field, and then press **Tab** to move to the **dZ** box.
  - d. Type **0.025** in the **dZ** field, and press **Enter**.

The History Tree updates to display **Cylinder1** with an underlying **CreateCylinder** command.

The **Properties** window's **Attribute** tab displays information about the newly created **Cylinder1** object.

4. If it is not already selected, click the **Attribute** tab to see the properties associated with the cylinder.
5. Change the name of the cylinder to **Hole**:
  - a. Click the **Value** text box in the **Name** row.
  - b. Type **Hole**, and press **Enter**.

Next, you will remove **Hole** from **GroundPlane**:

1. Ctrl+click the **Hole** and **GroundPlane** objects to select both.
2. Click **Modeler > Boolean > Subtract**.

The **Subtract** dialog box appears.

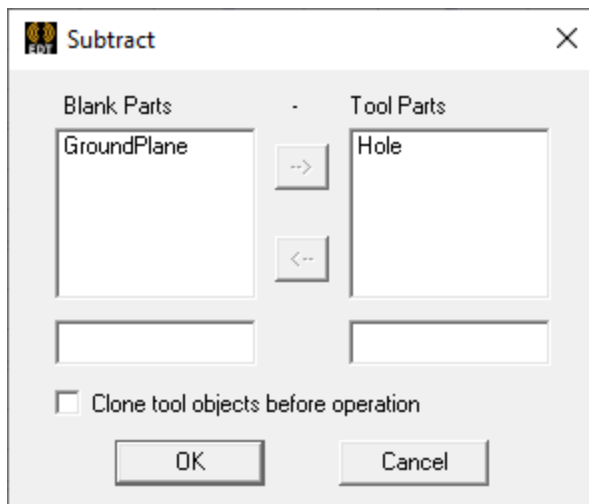

3. Use the arrows to ensure that **GroundPlane** is listed under **Blank Parts** and **Hole** is under **Tool Parts**.
4. Click **OK**.

A circular hole is created in **GroundPlane**. The model should look like the following:

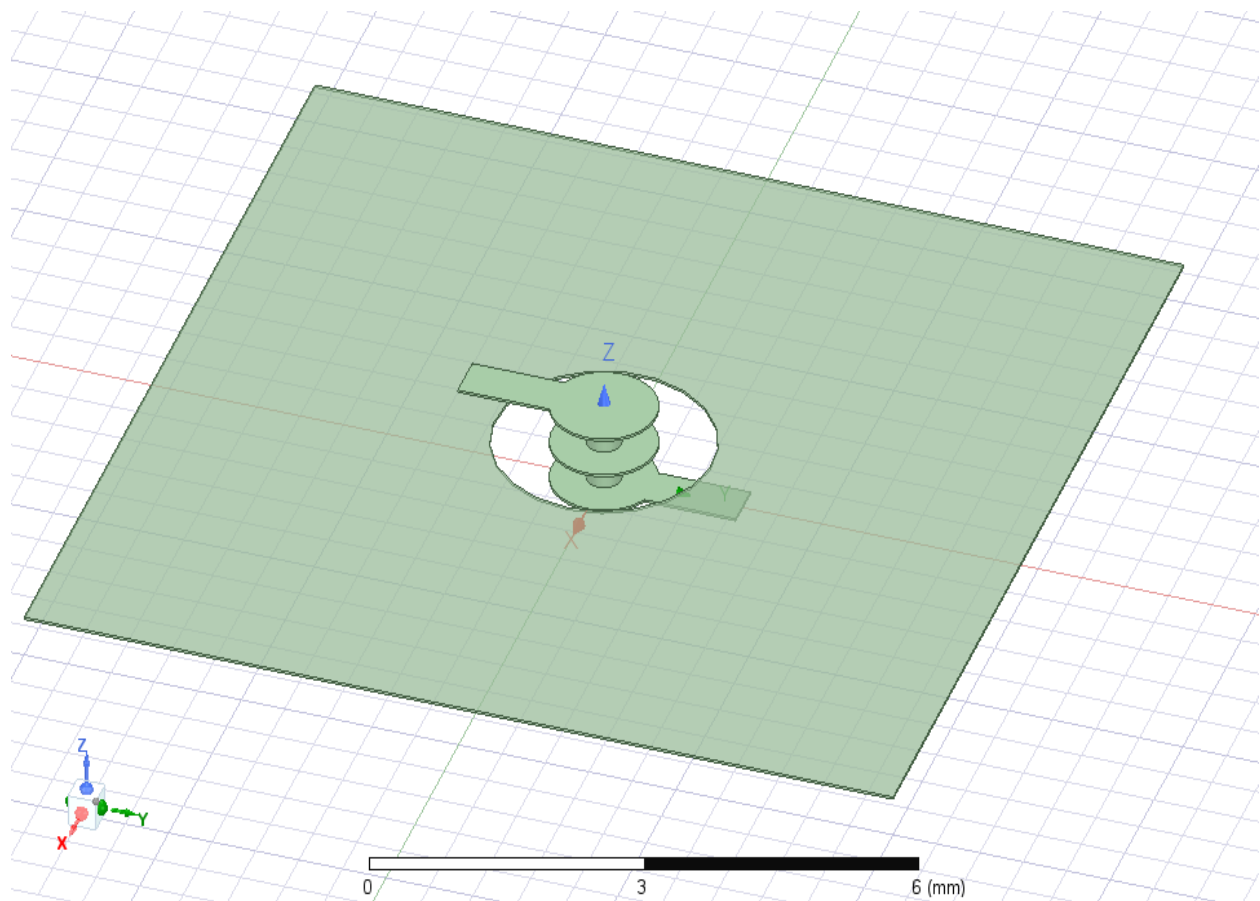

## Setting the Background Material

You have now completed all of the 3D drawing operations for the metal objects in the problem. By default, Q3D Extractor uses “vacuum” as the background material. However, for this project, the via must be modeled in an FR-4 substrate, so the surrounding material needs to be changed.

To change the background material:

1. Click **Q3D Extractor > Set Background Material**.

The **Select Definition** window appears.

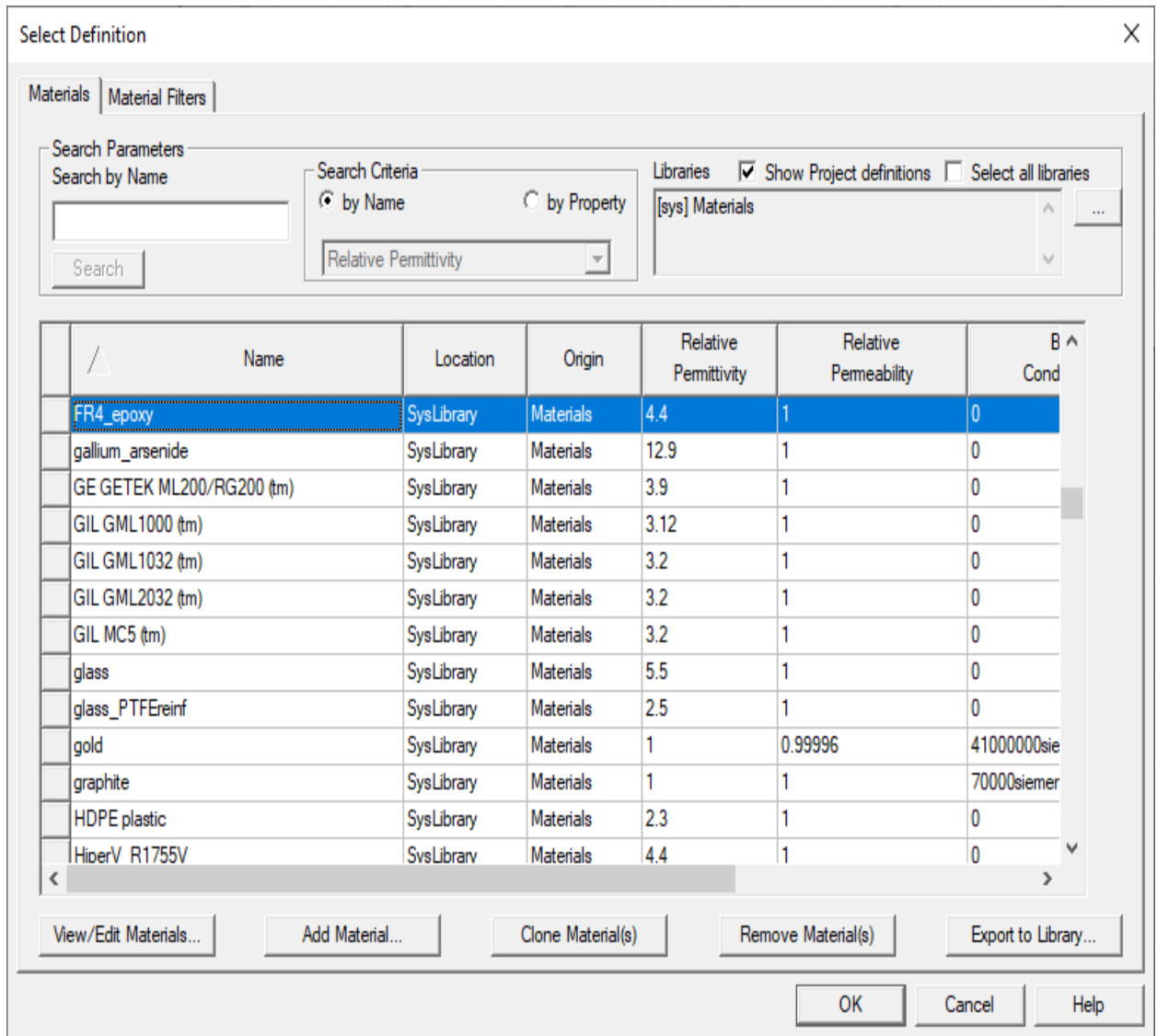

2. Select **FR4\_epoxy** from the list of materials, and click **OK**.



## 3 - Setting Up the Simulation and Viewing Results

This section explains how to perform the following tasks:

- Changing Q3D design settings
- Setting up sources and sinks for inductance and resistance calculations
- Identifying nets
- Adding a solution setup
- Validating the design
- Requesting the parameters (R, L, C) for which to solve and launching the simulation
- Viewing results as a field plot
- Exporting a Circuit model

### Changing Q3D Design Settings

To ensure frequency sweeps run correctly, you must use causal materials. Q3D Extractor can be set to automatically use causal materials from the Q3D Design Settings window:

1. Click **Q3D Extractor > Design Settings**.

The **Q3D Design Settings** window appears.

2. Select the **Lossy Dielectrics** tab.

3. Enable **Automatically use causal materials**.

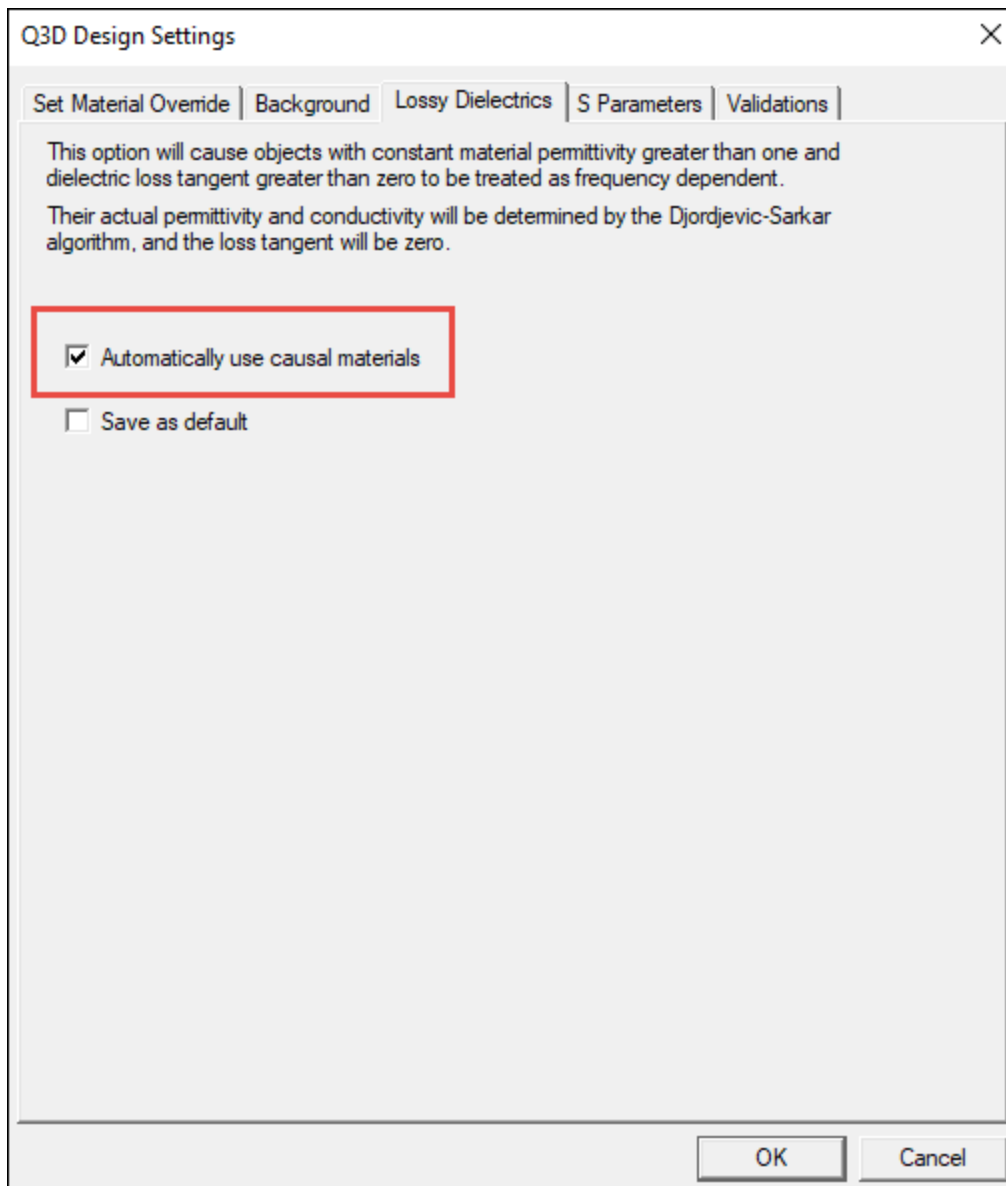

4. Click **OK**.

## Setting Up Sources and Sinks

To set up the solution for resistance and inductance, you will need to first define source and sink terminals. Attached to each source terminal is an independent current source. Assume that current enters and leaves at the ends of the two trace stubs you created. You need to put a source at the end of the top stub, and a sink at the end of the bottom stub.

## Defining the Source

1. Click **View > Visibility > Active View Visibility**.

The **Active View Visibility** dialog box appears.

2. Clear the **Visibility** check box for **GroundPlane**, and click **Done**.

**GroundPlane** disappears from view.

3. In the modeling workspace, select **Via**.

4. Click **View > Fit Selections > All Views**.

The model zooms so that **Via** fills the modeling workspace.

5. Rotate the model so that you are looking at the end of the top trace stub:

- Click **View > Interaction > Rotate Screen Center**, and then click-and-drag the model to spin it around.

6. Right-click in the modeling workspace and choose **Selection Mode > Faces**.

7. Click to select the face of the top stub.

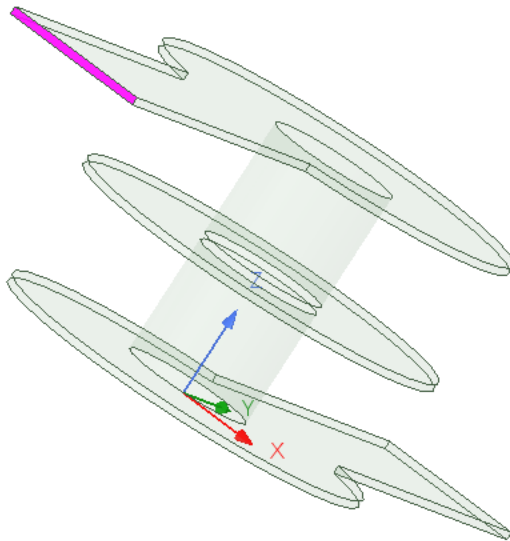

8. Right-click in the **Modeler** window, and then click **Assign Excitation > Source** from the shortcut menu.

The **Source** dialog box appears.

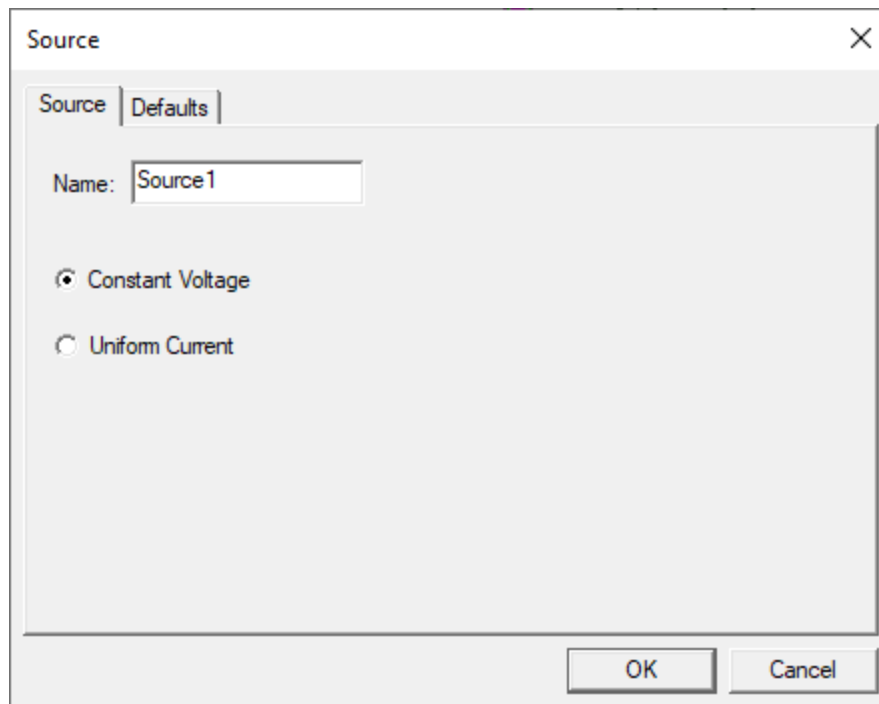

9. Leave the default settings and click **OK**.

## Assigning the Sink

The sink terminal collects all of the current injected at the source terminals and allows it to flow out of the conductor back into the independent sources, completing the electrical circuit.

1. Rotate the model so that you are looking at the end of the bottom trace stub:
  - Click **View > Interaction > Rotate Screen Center**, and then click-and-drag the model to spin it around.

2. Click to select the face of the bottom stub.

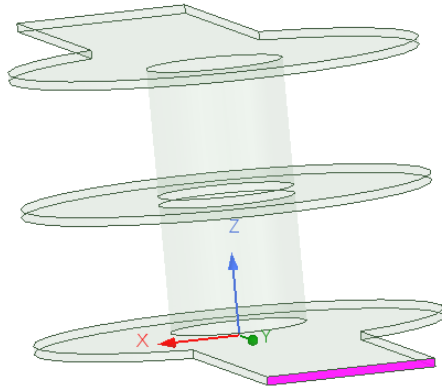

3. Right-click in the **Modeler** window, and then click **Assign Excitation > Sink** from the shortcut menu.

The **Sink** dialog box appears.

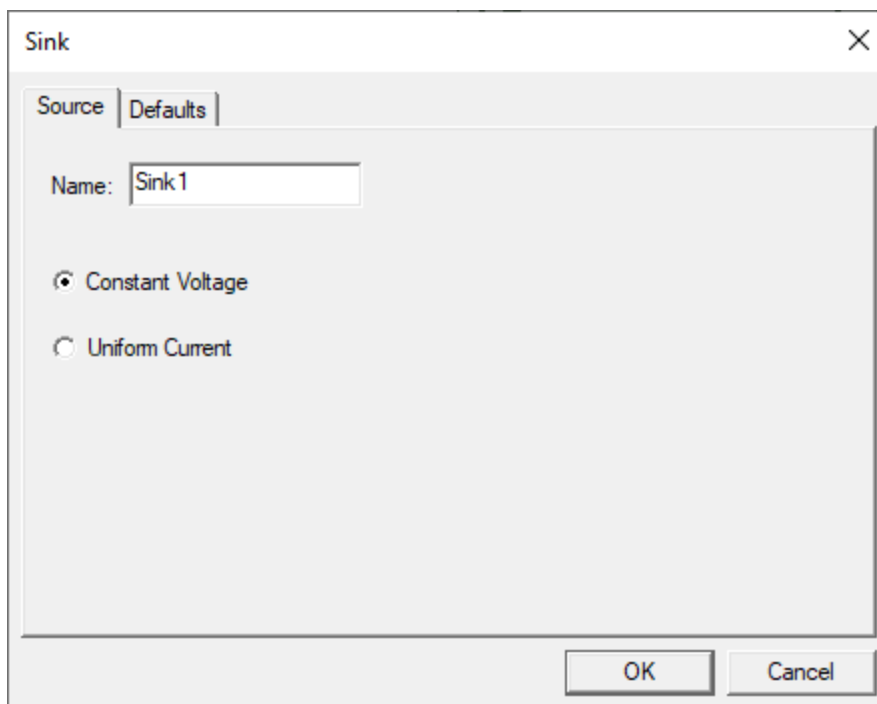

4. Leave the default settings and click **OK**.

Finally, restore ground plane visibility and orient the model:

1. Click **View > Visibility > Active View Visibility**.
2. Enable the visibility check box for **GroundPlane** and click **Done**.
3. From the **Draw** tab, select **Orient > Dimetric**.

The model should look like the following:

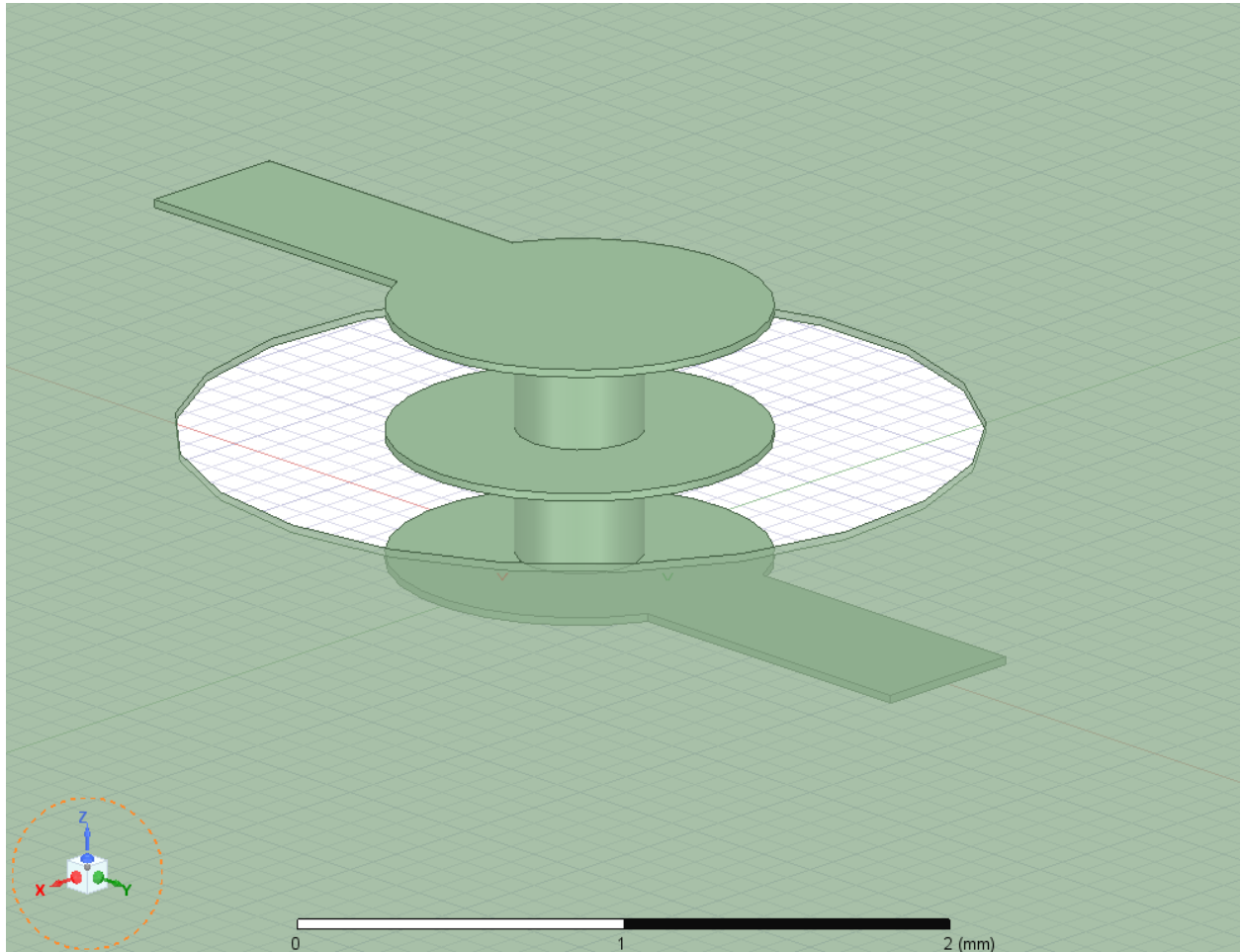

## Identifying the Nets

The model is almost ready for simulation. The final step is to define the distinct nets.

To automatically create nets:

1. Right-click in the modeling workspace and select **Auto Identify Nets**.

The Project Manager window updates to show two nets: **GroundPlane** and **Via1**. Beneath **Via1**, it shows **Source1** and **Sink1**.

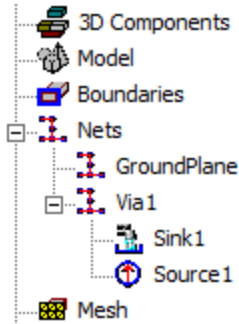

## Adding a Solution Setup

Now start solving for the electrical parasitics of the via.

1. In the **Project Manager** window, right-click **Analysis** and select **Add Solution Setup**.

The **Solve Setup** window appears.

2. On the **General** tab, verify that **Capacitance/Conductance**, **DC Resistance/Inductance** and **AC Resistance/Inductance** are selected.
3. Enable the **Save Fields** check box.

4. In the **Solution Frequency** field, specify **100 MHz**.

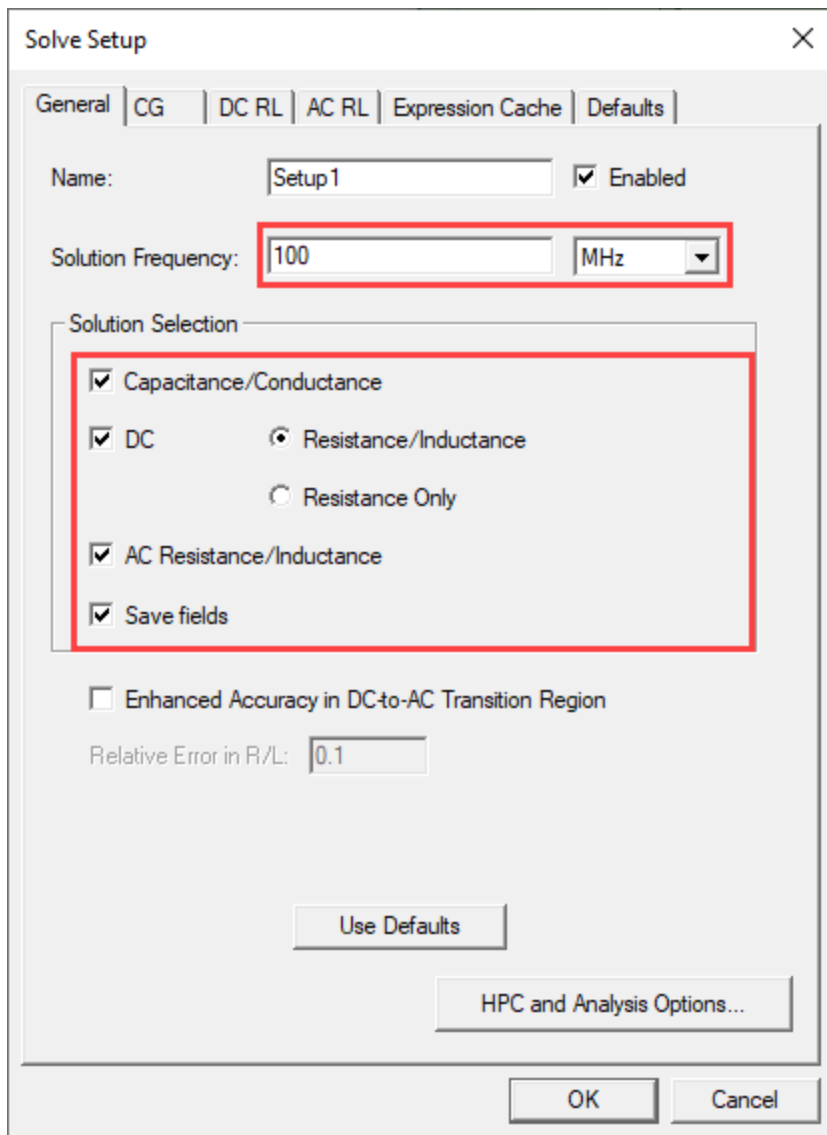

5. Click **OK**.

The new setup (Setup1) can be found under **Analysis** in the **Project Manager** window.

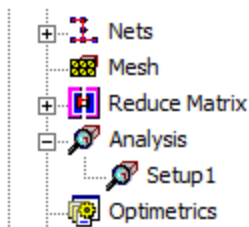

## Validating the Design

You must verify that all the steps have been properly completed before you launch the simulation.

1. Click **Q3D Extractor > Validation Check**.

The **Validation Check** dialog box appears, and displays a progress bar.

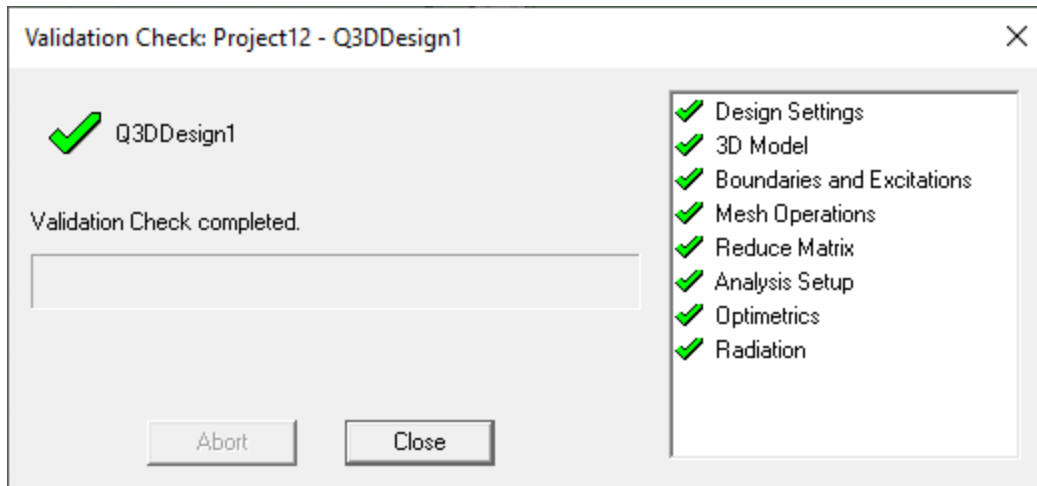

When the check is complete, the message 'Validation Check completed' appears.

If all checks were successful, only green check marks appear.

If a check has failed, a red X or yellow warning sign will appear.

Errors must be corrected before simulation.

2. Verify that the design has passed all checks. If it has no, return to the previous steps in this guide and look for missteps.

## Launching the Simulation

If you have no errors from the validation check, you are ready to launch the field solvers.

1. In the project tree, click **Analysis** to expand it.

**Setup1** is listed.

2. Right-click **Setup1**, and select **Analyze**.

Q3D begins to mesh and solve the problem. The **Progress** window displays a progress bar.

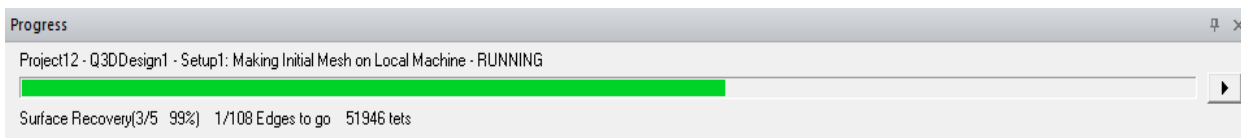

- To view details about the ongoing solution, right-click **Setup1**, and select **Convergence**. The **Solutions** window appears.

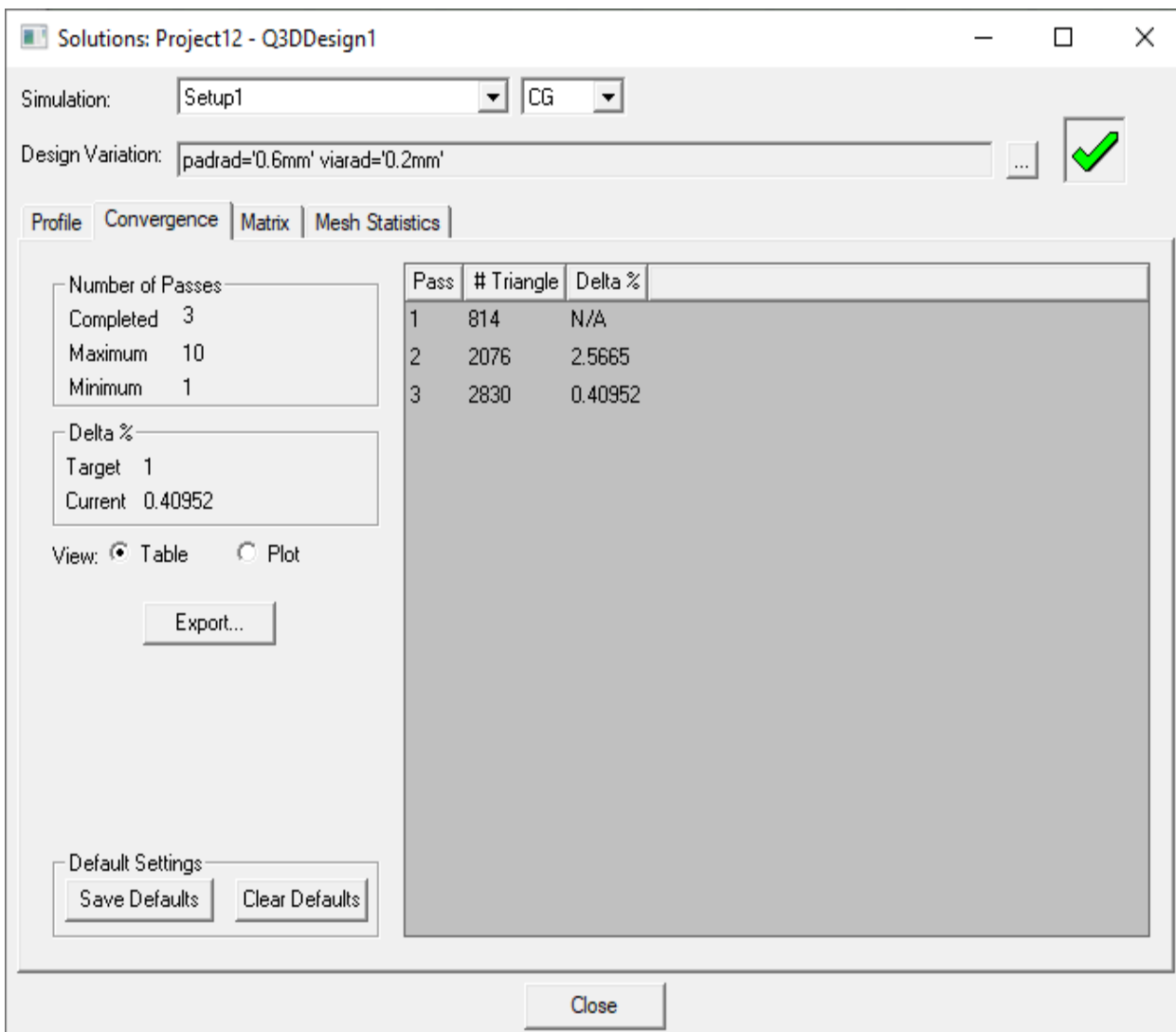

This window shows how the mesh grows from one adaptive solution pass to the next and how much the solution changes (delta%) between passes.

- Click the **Matrix** tab to see the actual capacitance solution data.

5. Click the **Profile** tab to see run-time profile information, such as the amount of CPU time or memory used in the solution.
6. Click **Close**.

## Generating a Field Plot

Field plots represent basic or derived quantities on surfaces or objects. You will now generate a field plot on **Via**.

1. In the modeling workspace, select **Via1**.
2. Select **Q3D Extractor > Fields > CG Fields > Q > SmoothQ**.

The **Create Field Plot** window appears.

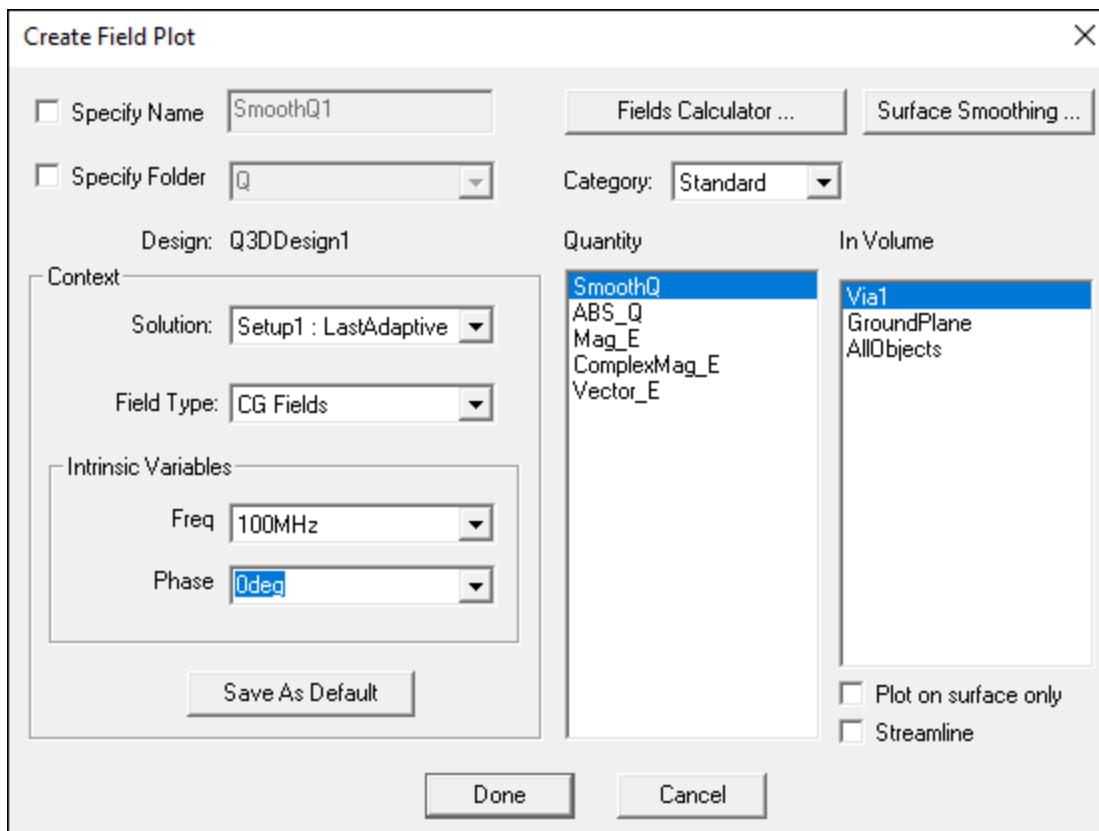

3. Leave the default values unchanged, and click **Done**.

The resulting plot shows the charge when 1V is applied to **Via** and 0V is applied to

## GroundPlane.

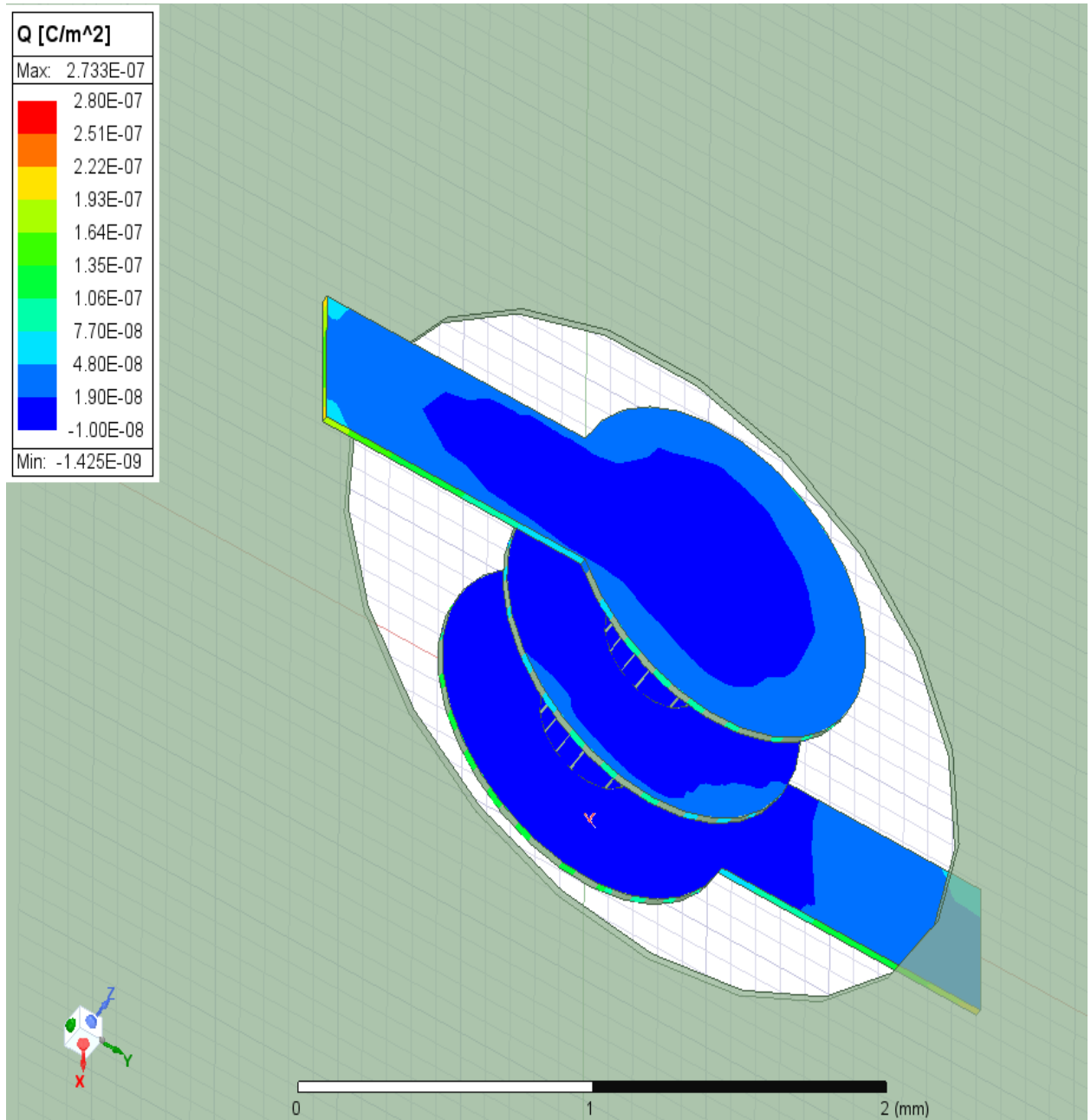

## Exporting a Circuit Model

Now that you have the solution, you will export a SPICE model to simulate the effects of the via on a signal that passes through it.

1. From the Project Manager, right-click **Setup1** and select **Export Circuit**.

The **Export Circuit** window appears.

2. Leave the default settings, and click **Export Circuit**.

The file is exported as *via\_gsg.cir*. A message window confirms the location and file name.

3. Click **OK**.

Currently, the model uses a single value for the variables *padrad* (0.6mm) and *viarad* (0.2mm).

Next, you will set up a parametric analysis to sweep the variables over a range of values. Then, you can export different equivalent circuit models corresponding to the different values of these variables.



## 4 - Setting Up a Parametric Analysis

This section explains how to perform the following tasks:

- Adding a parametric sweep
- Running the parametric analysis

### Adding a Parametric Sweep

A parametric setup is made up of one or more variable sweep definitions. A variable sweep definition is a set of variable values within a range that Optimetrics drives Q3D to solve when the parametric setup is analyzed. You can add one or more sweep definitions to a parametric setup.

1. Click **Q3D Extractor > Optimetrics Analysis > Add Parametric**.

The **Setup Sweep Analysis** window appears.

2. On the **Sweep Definitions** tab, click **Add**.

The **Add/Edit Sweep** window appears.

3. Use the **Variable** drop-down list to select **viarad**.
4. Ensure that **Linear Step** is selected.
5. Specify the following values:

<b>Start</b>	<b>0.2mm</b>
<b>Stop</b>	<b>0.5mm</b>
<b>Step Size</b>	<b>0.05 mm</b>

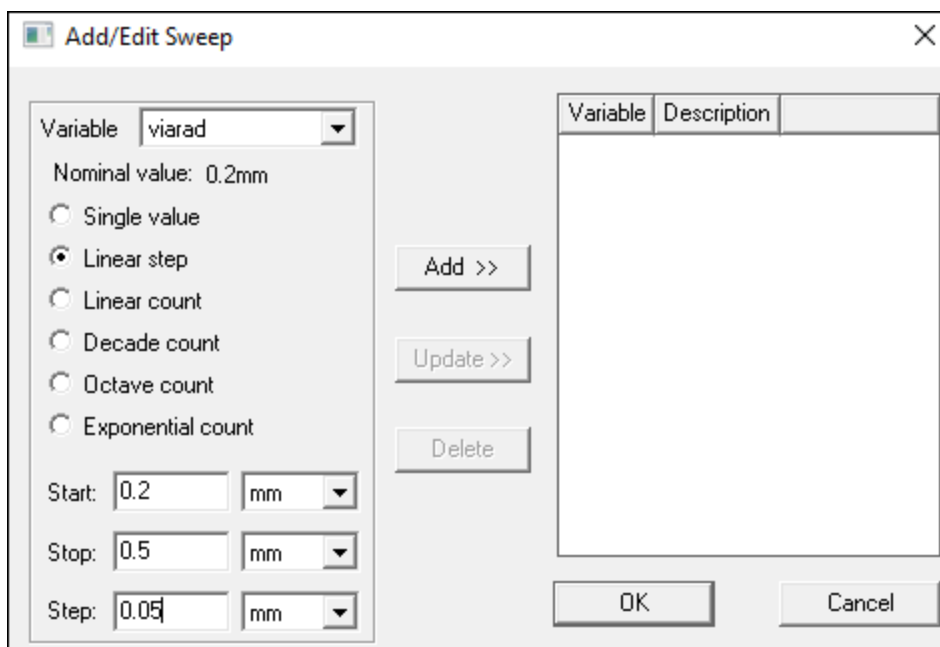

6. Click **Add**.

The variable **viarad** appears in the column to the right.

7. Click **OK** to exit the **Add/Edit Sweep** window and return to the **Setup Sweep Analysis** window.

The variable **viarad** now appears in the list.

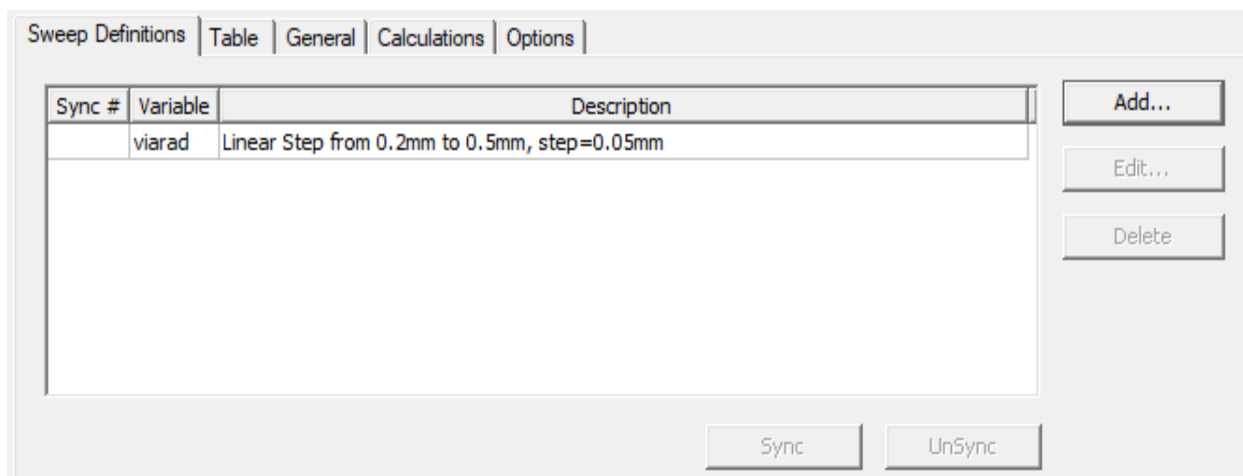

8. Click the **Table** tab to see all the values of **viarad** that will be simulated.
9. Click **OK**.

Q3D Extractor simulates the model with various values in the specified range, including the start and stop values.

The frequency sweep is listed in the **Project Manager** under **Optimetrics** as **ParametricSetup1**.

## Running the Parametric Analysis

Run the parametric analysis that was set up in the last step:

1. From the **Project Manager**, right-click **ParametricSetup1**, and select **Analyze**.  
The **Progress** window displays the progress.
2. When the analysis has finished, right-click **ParametricSetup1** and select **View Analysis Result**.

The **Post Analysis Display** dialog box appears, showing a table listing the values of **viarad** that have been solved.

3. Click the **Profile** tab to see how long it takes to solve each variation.

Variation	padrad	viarad	Start	Stop	Elapsed	Analysis Machine
1	0.6mm	0.2mm	15:05:...	15:05:...	00:00:...	Local Machine
2	0.6mm	0.25...	15:05:...	15:06:...	00:00:...	Local Machine
3	0.6mm	0.3mm	15:06:...	15:06:...	00:00:...	Local Machine
4	0.6mm	0.35...	15:06:...	15:07:...	00:00:...	Local Machine
5	0.6mm	0.4mm	15:07:...	15:08:...	00:00:...	Local Machine
6	0.6mm	0.45...	15:08:...	15:08:...	00:00:...	Local Machine
7	0.6mm	0.5mm	15:08:...	15:09:...	00:00:...	Local Machine



## 5 - Comparing Results

This section explains how to perform the following tasks:

- Creating a plot of the parametric sweep
- Changing the pad radius and viewing its effect on capacitance

### Plotting the Results

1. From the **Project Manager**, right-click **Results** and then select **Create Matrix Report > Rectangular Plot**.

The **Report** window appears, on the **Trace** tab.

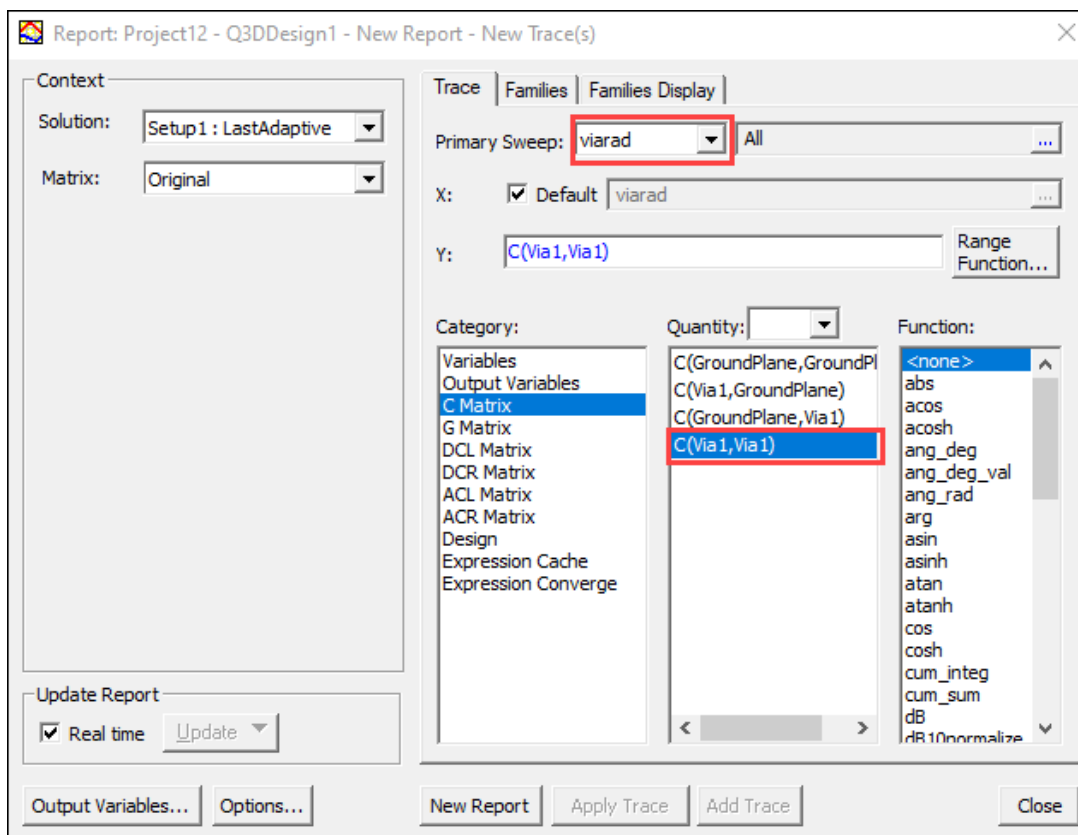

- In the **Quantity** list, select **C(Via1,Via1)**.
  - Use the **Primary Sweep** drop-down menu to select **viarad**.
2. Click **New Report**.

A graph appears. The X axis reads **viarad**, and the Y axis reads **C(Via1, Via1)**.

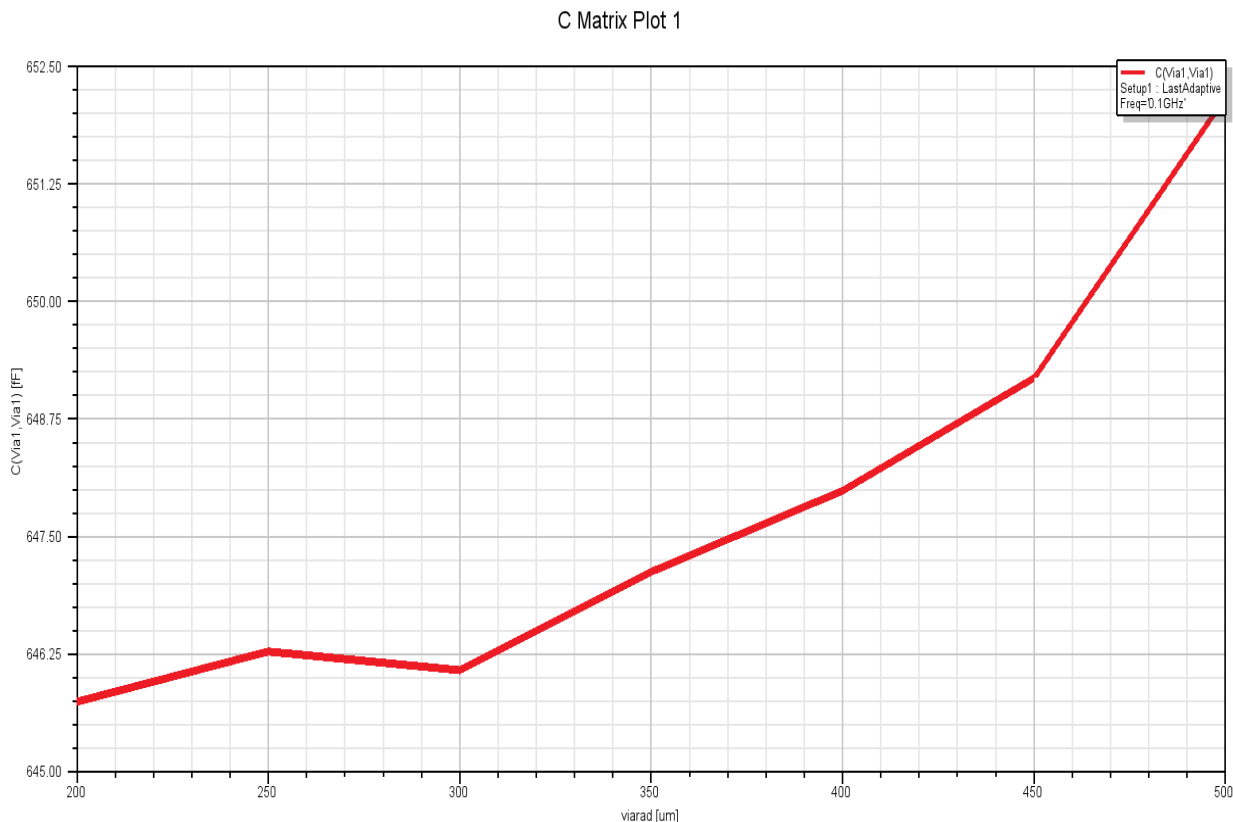

The graph shows that the via capacitance is only slightly affected by the radius of the center barrel: the change in capacitance is from 645.75 pF to 652.5 pF. There is about 0.2% variation in capacitance when via radius changes by a factor of 2.5 times (200 to 500).

Next, you'll generate another parametric sweep by changing the pad radius to see to its effect on the capacitance.

## Modifying the Pad Radius

1. Click **Q3D Extractor > Optimetrics Analysis > Add Parametric**.

The **Setup Sweep Analysis** window appears.

2. Under the **Sweep Definitions** tab, click **Add**.

The **Add/Edit Sweep** window appears.

3. Click **padrad** from the **Variable** pull-down list.
4. Verify that **Linear Step** is selected.
5. Specify the following values:

<b>Start</b>	<b>0.5mm</b>
<b>Stop</b>	<b>1.1mm</b>
<b>Step Size</b>	<b>0.1mm</b>

- Click **Add**.

The variable **padrad** appears in the list to the right.

- Click **OK** to exit the **Add/Edit Sweep** window and return to the **Setup Sweep Analysis** window.
- Click **OK** to close the **Setup Sweep Analysis** window.

The frequency sweep is listed in the **Project Manager** under **Optimetrics** as **ParametricSetup2**.

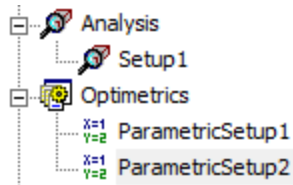

## Running and Plotting Second Parametric Analysis

Now you can run another parametric analysis.

- From the Project Manager, right-click **ParametricSetup2**, and select **Analyze**.

The **Progress** window displays a progress bar.

- When the simulation has finished, right-click **ParametricSetup2** and select **View Analysis Result**.

The **Post Analysis Display** dialog box appears, listing the values of **padrad** that have been solved.

- Close** the window.

Just as you did previously, plot this parametric analysis:

- In the **Project Manager**, right-click **Results** and select **Create Matrix Report > Rectangular Plot**.

The **Report** window appears, on the **Traces** tab.

- In the **Quantity** list, select **C(Via1,Via1)**.
- Use the **Primary sweep** drop-down menu to select **padrad**.
- Click the **Families** tab. Select the **Sweeps** radio button, and then select the **viarad** row.

5. Click the ellipses (...) button in the **viarad** row to specify sweep values for **viarad**:
  - Ensure that the Select Values radio button is enabled.
  - Ensure that 0.2mm is selected in the list. During the sweep, **viarad** will remain constant at 0.2mm.

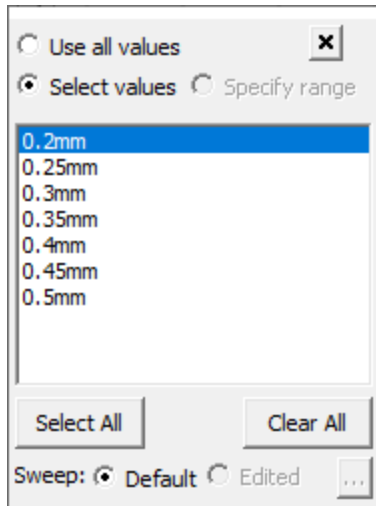

6. Click **New Report** to generate the graph.
7. Click **Close** to exit the **Report** window.

A graph appears, displaying the variation of the via capacitance (y axis) versus the pad radius (x axis).

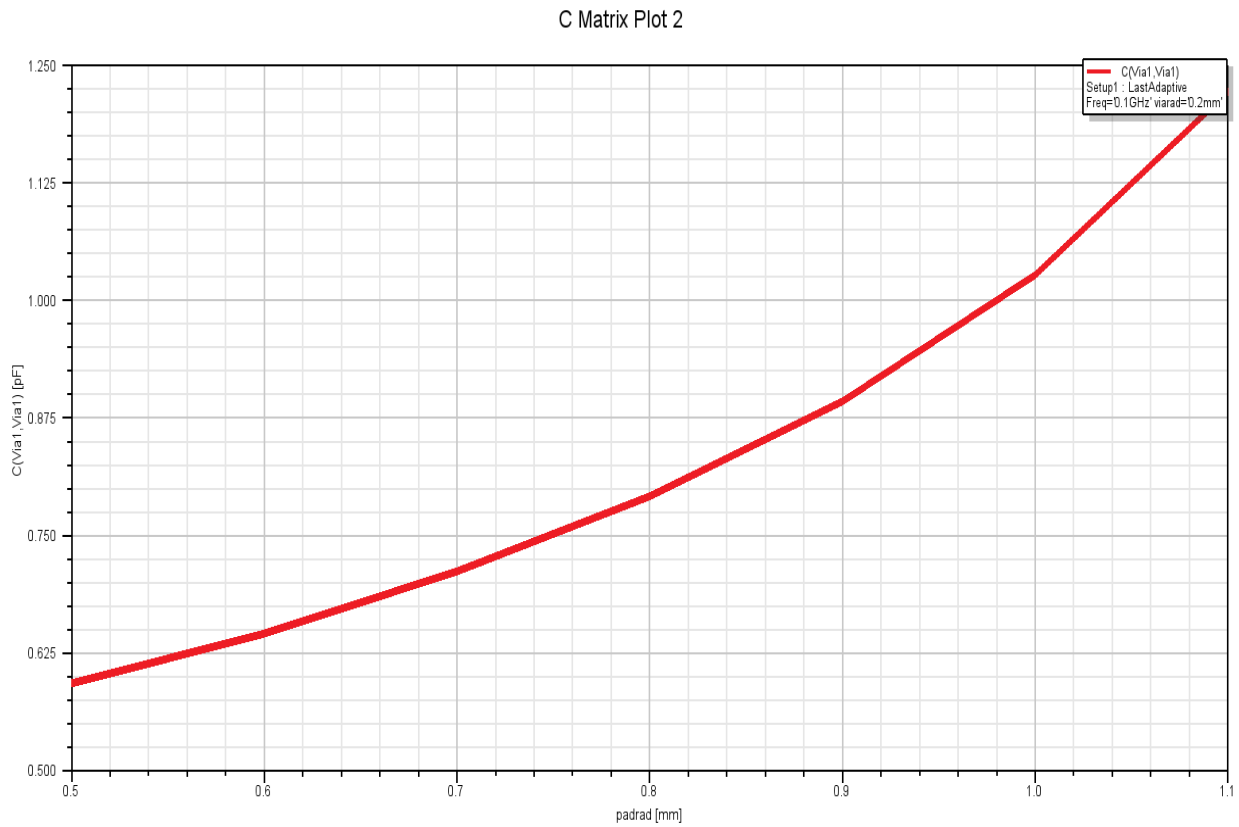

This graph shows a much stronger effect from the pad radius than from the center barrel radius. The capacitance changes from 0.585 pF to 1.250 pF (over 100% variation) over the range of the sweep.



## 6 - Closing the Project and Exiting Electronics Desktop

Congratulations! You have successfully completed the *Getting Started with Q3D Extractor: A PCB Via Model* guide. You may close the project and exit the software.

1. Click **File > Save**.
2. Click **File > Close**.
3. Click **File > Exit**.

**Note:**

If you enabled [Legacy View Orientation](#) earlier, you may wish to disable it now.